

Imaging of cortical spreading depression by EIT: implications for localization of epileptic foci

K Boone, A M Lewis and D S Holder
University College London, UK

Abstract. Severe epileptics may require curative neurosurgery. Sometimes focus localization requires recording with electrodes inserted deep into the brain, which may cause death or permanent neurological damage. Since epileptic seizures are associated with marked changes in cerebral impedance, we propose that EIT with sub-dural electrodes (inserted between the brain and skull) could provide a superior and less dangerous method for the localization of epileptic foci. The purpose of these experiments was to determine whether EIT could be used to localize the origin of seizure activity. In terms of impedance characteristics, an appropriate model is cortical spreading depression in the animal brain. Six rabbits were anaesthetized and paralysed and the brain exposed. EIT images and DC potentials were recorded from an array of 16 electrodes on the brain during cortical spreading depression induced by DC stimulus. Cortical spreading depression could be localized by EIT with an accuracy of $8.7\% \pm 6.4\%$ (mean \pm SD) of electrode array diameter. The errors in localization appeared to be distributed randomly. In a phantom of similar geometry, the error was 5% after correction for a systematic component. Results are sufficiently encouraging that we intend to extend this study to human patients.

1. Introduction

1.1. Electrical impedance tomography

Electrical impedance tomography (EIT) is a relatively new technique that may be used to form images of physiological function. A typical biomedical EIT system (Barber and Seagar 1987) injects current through a pair of electrodes and measures voltages from other pairs. For each image, 104 such measurements are made from a total of 16 electrodes. The image is generated from these measurements by mathematical techniques.

1.2. Localization of epileptic foci

The localization of epileptic foci is a possible application of EIT. Some cases of epilepsy may be attributed to a small discrete *focus* of epileptic activity in the brain. Drugs can be used to control the symptoms in the majority of patients, but some intractable cases require surgical resection of the focus. For this surgery to succeed, the focus must first be localized. Normal electroencephalography (EEG) with scalp electrodes is not generally useful in these cases (Binnie 1988); sub-dural and depth electrodes are often used. Depth electrodes in particular are associated with significant morbidity and mortality due to trauma and haemorrhage into the brain. In one study Van Buren (1987) reported permanent neurological damage in 0.8% of patients and other serious complications in 4%. In approximately 25% of cases, surgery fails to relieve symptoms (Polkey 1988), and this may perhaps be due to inadequate localization of the focus, or to the presence of multiple or diffuse foci.

Epilepsy, like many other physiological processes, can cause an impedance change in the brain. In pathological states, very large resistivity increases may be detected: up to 100% in

cerebral ischaemia (Hossman 1971) and 20% in epilepsy (van Harreveld and Schadé 1962). These are predominantly due to neuronal cell swelling (Hansen and Olsen 1980). Intense metabolic activity results in the cell being unable to maintain its low internal concentration of sodium, so water enters the cell due to the reduced intracellular osmotic potential. The extracellular space is reduced in size, and resistivity is correspondingly increased. It should therefore be possible to localize the focus of activity with EIT.

1.3. Potential use of EIT in epilepsy

EIT has been used experimentally to form images of the thorax, abdomen and limbs. Although bulk resistivity changes in the head have been imaged (McArdle *et al* 1989), EIT has not previously been used to image local variations of impedance within the brain. This is probably due to two complexities presented by the particularly large difference in resistivity between the bone of the skull (about 160 Ω m) and the tissues of the brain (average of grey and white matter about 5.8 Ω m) and scalp (figures from Barber and Brown (1984)). (i) The current density in the brain will be considerably reduced with respect to that in the scalp, and the voltage changes that result from resistivity changes in the brain will be small. (ii) The Sheffield Mark 1 reconstruction process makes an assumption that the resistivity changes occur against a uniform resistivity background. While non-invasive use of EIT for localizing epileptic foci would, of course, be convenient, it would be very difficult to implement with currently available EIT equipment. We propose that sub-dural electrodes might be used in this application. Such electrodes are routinely used prior to surgery and do not significantly increase the risk to these patients. EIT should therefore provide safer and more accurate localization of epileptic foci. Morbidity would be reduced because the need for depth electrodes would be eliminated. Accuracy would be improved since the electrodes do not need to be immediately adjacent to a focus for it to be imaged. EIT may also show multiple or diffuse foci better than existing techniques. Its advantages over techniques such as PET and NMR are that (i) it is very much cheaper (a few thousand pounds), (ii) it has potentially very good time resolution (< 1 s per image) and (iii) it is portable; the hardware could be miniaturized to such a size that it could be worn by the patient for chronic monitoring.

1.4. Experimental design

The purpose of these experiments was to determine whether, and how well, EIT may be used to image large-scale functional changes in cerebral resistivity. We were particularly interested in quantitative measures of its ability to localize a focus of activity, since this is of particular relevance to our proposed clinical application. By comparison with measurements in a phantom, we attempted to determine the sources of error in the EIT images and the implications these present for the use of EIT for localizing epileptic foci in human patients.

In these experiments, EIT image data were collected from a ring of electrodes placed on the brain during the phenomenon of cortical spreading depression in anaesthetized rabbits. Cortical spreading depression was first described by Leão (1944). It may be initiated by various stimuli (Marshall 1959): chemical, thermal, mechanical and, as in these experiments, electrical. A wavefront of activity then spreads outwards at about 3 mm min⁻¹ (figure 1(a)). It can be produced in grey, but not white, matter anywhere in the brain (Grafstein 1956); in these experiments, it was only elicited in the cerebral cortex. It does not cross the midline of the brain, probably because the region of the longitudinal fissure does not contain sufficient grey matter to support it. It is thought that propagation of cortical spreading depression is caused by passive diffusion of excitatory substances ahead of the active region (Burês

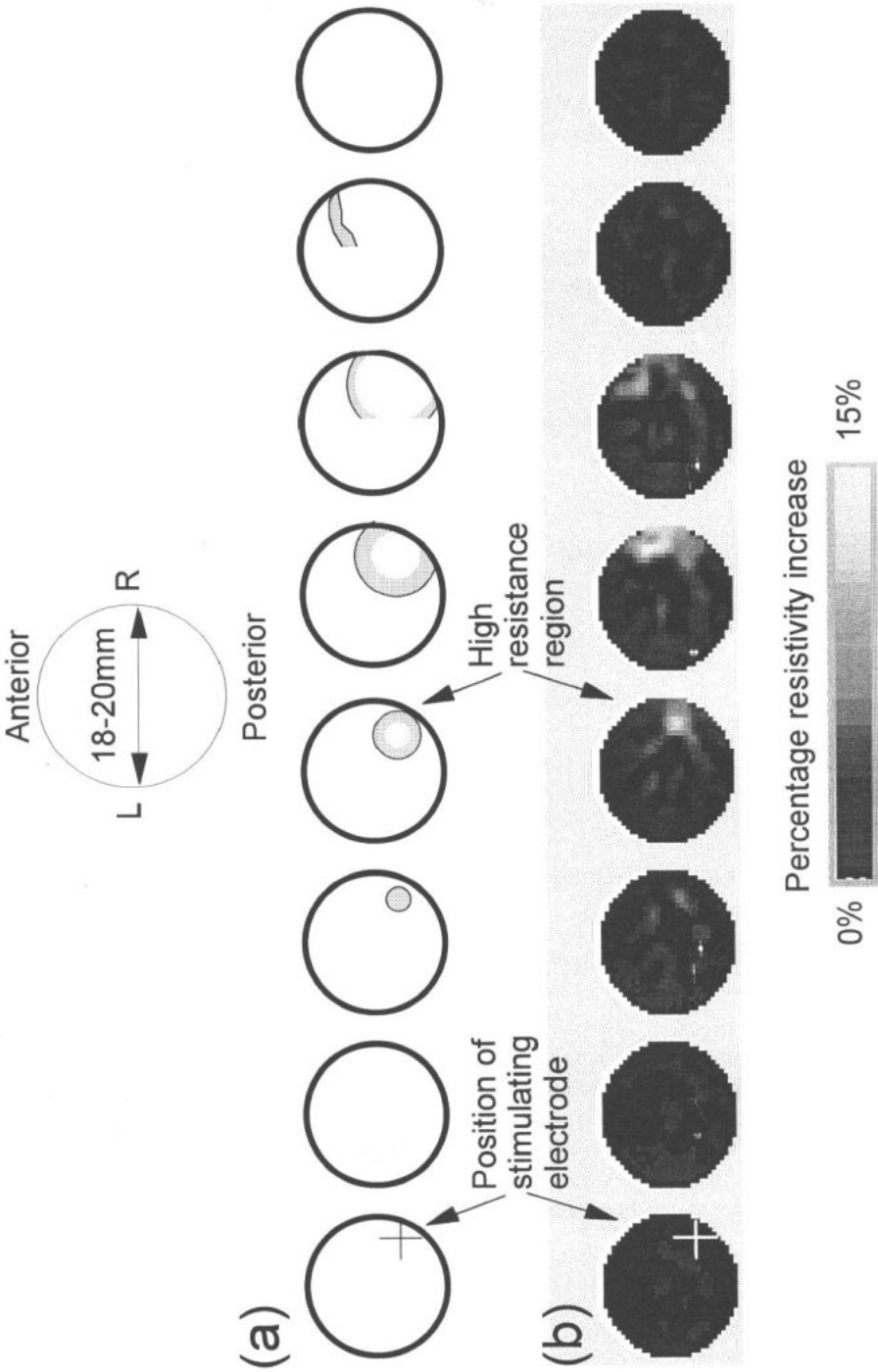

Figure 1. An example of an image sequence recorded from the rabbit brain: (a) the expected spread of the high-resistance area; (b) reconstructed EIT images; s. Image frames are separated by 30 s. The cross on the first image represents the measured position of the stimulus.

1974). For the purposes of EIT imaging, cortical spreading depression is an appropriate model of epilepsy since it has similar impedance characteristics (Marshall 1959), although the increases are somewhat larger: up to 100% (Hoffman *et al* 1973). These impedance increases are probably due to cell swelling (Hansen and Olsen 1980). Unlike epilepsy, spreading depression is characterized by a sequence of well defined cortical DC potential changes so EEG monitoring is not required during measurements. This is an advantage because, in our experience, signals of EEG frequencies are inadvertently injected by the Sheffield Mark 1 EIT system.

In the rabbit the cortex forms a disc 1–2 mm deep, while the rest of the brain has the approximate shape of an inverted hemisphere (figure 2). The active region is therefore confined to a thin disc around whose periphery the electrodes are placed. The Sheffield Mark 1 algorithm assumes that the subject has homogeneous resistivity and is two dimensional. These requirements are satisfied to some extent by this preparation, so an accuracy comparable to that achieved in a saline-filled tank might be expected.

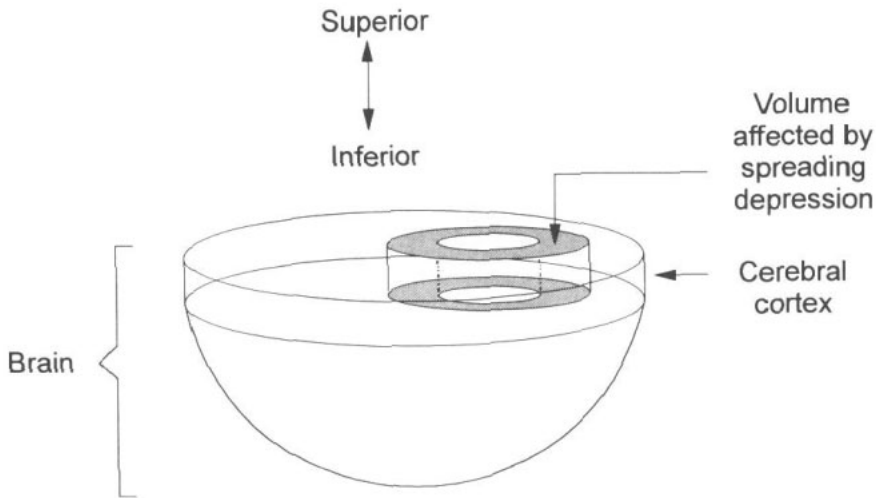

Figure 2. The rabbit brain. Only the cortex is affected by cortical spreading depression (shaded area).

When the cortex is exposed, it is necessary to keep it moist to prevent damage due to drying; a solution similar in composition to cerebro-spinal fluid is normally used. Moistening the brain with a conductive solution will, however, will change its resistivity dramatically. In some experiments therefore, the *dura mater* was left intact, obviating the need to moisten the brain. Imaging with the intact *dura* also provided an opportunity to determine whether the extra tissue layer between brain and electrodes affected the imaging performance.

2. Methods

2.1. Animal studies

Six adult New Zealand White rabbits were anaesthetized as follows: induction with Hypnorm (Janssen Animal Health) 0.3 ml kg⁻¹ intra-muscular and diazepam 2 mg kg⁻¹

subcutaneous; maintenance with 0.5%–2% halothane in 50%/50% nitrous oxide/oxygen mixture; neuromuscular blockade with pancuronium bromide 0.05 mg kg⁻¹. The animals were ventilated with a small animal ventilator (Scientific Research Instruments Ltd). Arterial blood pressure and end-tidal expiratory percentage CO₂ were measured continuously; arterial blood gases were measured several times during an experiment. The brain was exposed by removing a circular section of cranium approximately 25 mm in diameter. In two experiments the *dura mater* was carefully resected. Where the *dura mater* was removed, the brain was irrigated at approximately 5 min intervals with an 'artificial cerebro-spinal fluid' solution (147 mmol l⁻¹ sodium chloride; 3 mmol l⁻¹ potassium chloride). Where the *dura mater* was not removed, it was sometimes difficult to elicit cortical spreading depression, presumably because cerebro-spinal fluid trapped under the *dura* was shunting the current and so diminishing the current density at the stimulation site. The cerebro-spinal fluid was therefore allowed to drain spontaneously by pricking the *dura mater* with a needle at a distant site.

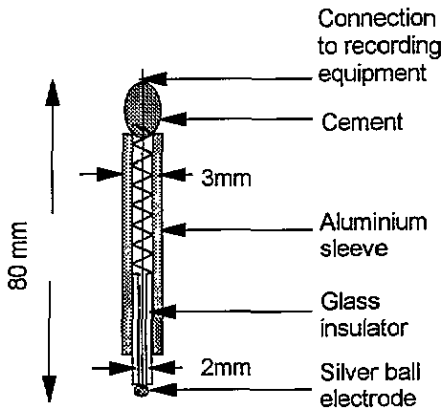

Figure 3. The construction of the spring-loaded electrodes used on the rabbit brain.

An array of 16 silver/silver chloride ball electrodes was lowered onto the exposed brain (figure 3). Each electrode was spring loaded in an attempt to prevent pressure being placed on the brain. Each ball had a surface area of about 0.8 mm². The electrodes were connected to the Sheffield Mark 1 (IBEES, Sheffield) data collection system, and to a DC data acquisition system (Keithley Instruments Inc., Series 500), which sampled at 1 Hz. To use the Sheffield Mark 1 system in this configuration, it was modified so that the applied current could be selected from the front panel. The current was set at the highest value that did not cause saturation of the input amplifiers. In practice this was 0.5–1.0 mA (peak) since the inter-electrode resistance is higher than normally encountered in EIT measurements. Before each measurement the gain, phase and current drive level of the EIT system were set up to give the highest 'Check 1' figure (lowest worst-case reciprocity error) that could be obtained without saturation. Cortical spreading depression was initiated by a DC cathodal stimulus of 0.6–1.5 mA for 30–60 s. The stimulus strength used was the lowest that was sufficient to induce spreading depression in each case. We recorded EIT data and DC potentials for 5 min before and 10 min after each stimulus.

2.2. Phantom experiment

A perspex beaker of diameter 25 mm and height 25 mm was used as a phantom to serve as a comparison for the animal results. This was filled with 0.2% saline, and a 1 mm diameter perspex rod used as a test object. The rod was submerged to a depth of 2 mm; this is the expected depth of the affected region of the brain. The same electrode array and equipment settings were used as for the animal experiments. Using a micromanipulator, the rod was carefully centred between the electrodes. The first image was taken when the rod was displaced 6 mm from the centre at an angle of 30° to a line between electrode 1 and electrode 9. Subsequent image frames were recorded as the rod was displaced in 1 mm increments towards and past the centre.

2.3. Data analysis

Images were reconstructed using the Sheffield Mark 1 algorithm. Because the images from the animal experiments were subject to large drifts and 'noise' with a period of 15–60 s, the site of initiation of activity was determined from the reconstructed images in the following way. The variation over time of each image pixel in the image was examined, and the focus was taken as the pixel detected whose resistivity increase (i) had a magnitude of at least 5% above baseline, (ii) started within 30 s of stimulus and (iii) returned to baseline within 2 min. In the phantom experiment, the position of the test object was calculated from the position of the resistivity peak in the image by a variation of the *expected value* formulae (Armitage 1971) to reduce the error due to noise.

2.4. Analysis of baseline variation

Most physiological resistivity measurements are subject to some baseline fluctuation; it is possible that such variations may influence the ability to localize focal activity. Baseline drifts in these experiments were compared by taking the mean level of the 104 voltage values in each EIT data frame as being indicative of the baseline state at that time. For viewing and presentation of the images from the animal experiments, a linear baseline correction was applied as follows. Four images immediately before the stimulus and another four about 10 min after were selected. For each pixel in the image, a least-squares procedure was used to find a line of best fit to these eight data points. The slope and intercept of this line were then used to correct this pixel in all the images in the sequence. This procedure, as well as the analysis described above, was performed on a PC-compatible computer using software written by the authors.

3. Results

3.1. Animal studies

Predominantly linear baseline drifts were evident in most recordings. The baseline drifts in epidural recordings were always smaller than those made on the exposed cortex (figure 4). After correction for baseline drift a consistent pattern of resistivity increase could be observed. Before stimulation the resistivity was relatively constant over the image (figure 1, frames 0–1). Shortly after the stimulus an initial discrete resistivity increase could be observed, which corresponded to the measured site of initiation (frame 2). The peak resistivity increases were 5%–25%. This high-resistivity area then expanded (frames 3–4). Subsequent spread was variable; it was more pronounced towards the periphery and

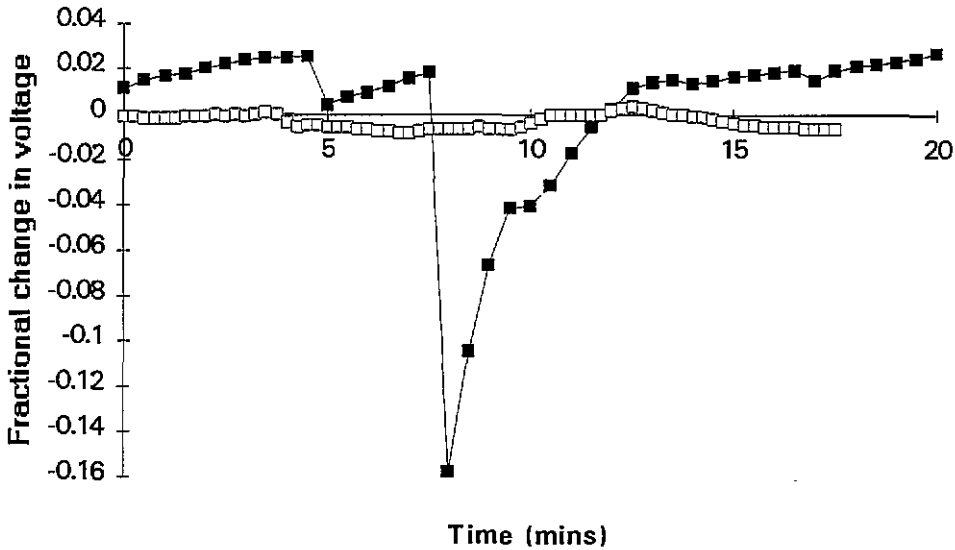

Figure 4. A comparison of the single best and worst baseline drift characteristics from this series of experiments: normalized mean voltage change (ratio) against time. ■, worst baseline drift; □, best baseline drift.

had a time course corresponding to a propagation speed of about 3 mm min^{-1} (frames 5–6). The resistivity eventually returned to the baseline level (frame 7). 17 cortical spreading depression events in six animals that met the following criteria were analysed for localization error: (i) the propagation speed of the spreading depression wavefront was calculated to be between 2 and 5 mm min^{-1} ; (ii) the mean arterial blood pressure was greater than 9.3 kPa (70 mm Hg). The error (mean \pm SD) between the peak of this initial resistivity increase and the known site of initiation was $5.9 \pm 2.8\%$ ($n = 5$) and $11.5 \pm 10\%$ ($n = 12$) for cortical and epidural recordings respectively. The small data set size and non-parametric nature of the error distribution makes testing for the differences between the two experimental conditions somewhat problematic. If the observed errors are divided into two ranges ($< 12\%$ and $> 12\%$) then Fisher's exact probability test yields $p = 0.255$ (two tailed). The two sets of results are therefore taken to be not significantly different and they are pooled for subsequent analyses. The overall mean localization error was therefore $8.7\% \pm 6.4\%$. There was no clear correlation between the radial and angular components of error and distance of the focus from the centre of the image.

3.2. Phantom experiments

The localization error for the perspex rod in saline was $7.6\% \pm 1.3\%$ ($n = 10$). The angular component of error was not obviously correlated with the distance from the centre. The radial error, expressed as a fraction of distance from the centre, was approximately constant. After correction for this effect the mean error was reduced to 5.0%.

4. Discussion

4.1. Summary of results

Experiments were performed to test the quantitative accuracy of EIT in localizing focal

activity in the exposed brain. We found that these large resistivity changes can be located with reasonable accuracy (mean 8.7%), but not as well as in a physical phantom of similar geometry. The results from the physical phantom could be improved (to 5.0%) by a correction for systematic error.

4.2. *Effect of dura mater on localization*

We found that there was no significant difference between the error performance with the cortex exposed and that with the *dura mater* intact. Baseline drift was improved when the *dura* was intact, presumably because the rate of drying of the brain was smaller. This suggests that future experiments would be technically easier to perform if the *dura mater* were kept intact.

4.3. *Sources of localization error*

Factors that might be expected to produce systematic errors include the following: (i) departures from the ideal circular geometry expected by the reconstruction process; (ii) anisotropy in the neural tissue—the fibrous nature of white matter makes anisotropy possible, but the resistivity changes in which we were interested were confined almost entirely to the grey matter (Grafstein 1956), which is not thought to be significantly anisotropic (Hoffman *et al* 1973); (iii) inhomogeneities in the tissue produced, for example, by surgical injury. Of the radial and angular error components, only the radial component in the phantom experiment was sufficiently systematic to suggest that a straightforward correction might improve localization. The test object appears consistently closer to the centre than in reality, and the position of the object in the image can be corrected by increasing its radial position by 30%. This is consistent with other quantitative studies (Eyüboğlu *et al* 1991). A correction of this sort could not be applied to the *in vivo* results. This suggests that any systematic errors in these experiments were smaller than random ones.

Possible sources of random error are as follows. (i) Baseline drift may affect localization accuracy for at least two reasons. Firstly, it is difficult to see the feature of interest, although baseline correction generally allows the focus to be enhanced. Secondly, the large variations in resistivity across the brain may undermine the reconstruction algorithm, which requires a reasonable degree of homogeneity of resistivity. In human patients the skull will be closed during measurement. If, as seems probable, the baseline drift in these experiments was due to drying of the brain, then baseline drift in humans can be expected to be at least as low as the best figures in these experiments. (ii) There were stimulus artifacts in some recordings. Although we used a battery-operated stimulator with its own return lead, it is still possible that a potential difference was developed between measuring electrodes during stimuli. This may have been sufficient to change the level of chloriding of the electrodes. This would change the electrode contact resistivity, and result in a small voltage distortion if the current source driving the electrodes were not ideal. In future animal experiments, this problem could be abolished simply by disconnecting the EIT electrodes during stimuli. In human patients, stimuli will not be given; these patients have frequent spontaneous seizures. (iii) It is technically very difficult to measure the position of the stimulating electrode on the brain; the electrode connections are very dense, and the brain is not perfectly smooth. The uncertainty in these positional measurements is probably of the order of $\pm 5\%$ – 10% .

4.4. *Implications for use in human patients*

Of the sources of error that affected the animal experiments, the following will also be applicable to human studies. (i) Systematic error: using the Sheffield reconstruction

algorithm, any EIT configuration whose current pattern does not correspond to that of an ideal cylindrical two-dimensional conductor will give rise to some systematic distortion of the image. Furthermore, this distortion will be *geometry dependent*. It may be possible to provide an image reconstruction process that compensates for the geometry of the patient's head. (ii) Random error: the signal-to-noise ratio may be inadequate; we will not be able to use current levels as high in human patients, so boundary voltages will be considerably reduced.

A factor that will be present in humans but was not important in the animal studies is movement artifact. During a seizure some patients make spontaneous movements and these may give rise to an apparent resistivity change if electrode contact with the brain is varied.

The main sources of error in this study appear to be random. This suggests that, for further *in vivo* studies, improvements to sources of systematic error, such as the reconstruction technique, are likely to be less important than attempts to reduce the random errors.

5. Conclusion

We have shown for the first time that EIT is capable of forming images of neural functional activity, at least when large resistivity changes are produced. Focal activity is shown very well; diffuse activity less clearly. Some of the sources of error in localization of foci, such as drying of the brain and stimulus artifact, will probably not affect human studies. These may, however, be affected by different sources of error that were not studied in the animal experiments.

These results are sufficiently encouraging that trials on human patients are justified; we have obtained ethical approval for the use of EIT with subdural electrodes in epileptic patients prior to surgery. We are also investigating the use of EIT for non-invasive localization of epileptic foci with extra-cranial electrodes.

Acknowledgments

KB is supported by the Science and Engineering Research Council, AML was supported by the Medical Research Council and DSH is supported by a Royal Society University Research Fellowship.

References

- Armitage P 1971 *Statistical Methods in Medical Research* (Edinburgh: Blackwell) pp 395–6
- Barber D C and Brown B H 1984 Applied potential tomography *J. Phys. E: Sci. Instrum.* **17** 723–33
- Barber D C and Seagar A D 1987 The Sheffield data collection system *Clin. Phys. Physiol. Meas.* **8** (Supplement A) 91–8
- Binnie C D 1988 *Electroencephalography A Textbook of Epilepsy* ed J Laidlaw, A Richens and J Oxley (Edinburgh: Churchill Livingstone) pp 236–306
- Burês J, Buresova O and Krivanek K 1974 *The Mechanism and Application of Leão's Spreading Depression of Electroencephalographic Activity* (New York: Academic)
- Eyübođlu B M, Brown B H and Barber D C 1989 Limitations to SV determination from APT images *Proc. 11th Ann. Conf. IEEE EMBS* (New York: IEEE) pp 442–3
- Grafstein B 1956 Locus of propagation of spreading depression *J. Neurophysiol.* **19** 309–16
- Hansen J H and Olsen C E 1980 Brain extracellular space during spreading depression and ischaemia *Acta Physiol. Scand.* **108** 355–65

- Hoffman C J, Clark F J and Ochs S 1973 Intracortical impedance changes during spreading depression *J. Neurobiol.* 4 471-86
- Hossman K 1971 Cortical steady potential, impedance and excitability changes during and after total ischaemia of cat brain *Exp. Neurol.* 32 163-75
- Leão A A P 1944 Spreading depression of activity in cerebral cortex *J. Neurophysiol.* 7 359-90
- Marshall W H 1959 Spreading cortical depression of Leão *Physiol. Rev.* 39 239-79
- McArdle F J, Brown B H and Angel A 1989 Imaging resistivity changes of the adult head during the cardiac cycle *IEEE EMBS, Proc. 11th Annual Int. Conf.* (New York: IEEE) pp 480-1
- Polkey C 1988 *Neurosurgery A Textbook of Epilepsy* ed J Laidlaw, A Richens and J Oxley (Edinburgh: Churchill Livingstone) pp 490-510
- Van Buren J M 1987 Complications of surgical procedures in the diagnosis and treatment of epilepsy *Surgical Treatment of the Epilepsies* ed J Engel Jr (New York: Raven)
- Van Harreveld A and Schadé J P 1962 Changes in the electrical conductivity of cerebral cortex during seizure activity *Exp. Neurol.* 5 383-400