



Leading education
and social research
Institute of Education
University of London

UPMAP 2008 Physics Year 10

Date:

D	M	Y
		08

Please note the time that you started to read this questionnaire:

Dear Student,

Please read this section before you begin

In this questionnaire, we want to find out more about the reasons some students continue to study physics after the age of 16 and others do not. We are asking you for some personal details, such as your name because we are interested in how students' answers may change over time and we hope that you will help us again by answering similar questions in about two years' time. There are questions in here about your views on school, family and physics. There are also some physics-based tasks, but we would like to emphasise these have nothing to do with your school marks. We simply would like to compare your answers to these task items with your attitudes to physics.

We hope you will answer all the questions but if you feel uncomfortable with a particular question feel free to skip it.

All answers are confidential.

Your teachers and your school will not see your answers.

Thank you for helping us!

1. ABOUT YOU

- a) In which year do you think you will be taking your physics GCSE? Please tick.
- | | | | |
|--------------------------|--------------------------|--------------------------|--------------------------|
| Year
9 | Year
10 | Year
11 | Don't
Know |
| <input type="checkbox"/> | <input type="checkbox"/> | <input type="checkbox"/> | <input type="checkbox"/> |
- b) How many brothers and sisters do you have?
- c) How many are younger than you? d) How many are older?
- e) What is your gender? Male Female
- f) What is your first name?
- g) What is your surname?
- h) What is your date of birth? Day Month Year
- i) What is the name of your school?
- j) Which physics set are you in?
- k) Which science class are you in?
- l) How many different physics teachers have you had since you started this school?
- m) How many different schools (primary & secondary) have you attended, including this one?

n) What are your parents'/carers' occupations?	Mother or Carer 1	Father or Carer 2
1) Professional (e.g. manager, doctor, teacher, dentist, nurse, ...)	<input type="checkbox"/>	<input type="checkbox"/>
2) Clerical and skilled non-manual (e.g. Secretary, clerk, typist, receptionist, Civil Service and Local Government Employee (Administrative, Executive and Clerical Grades), ...)	<input type="checkbox"/>	<input type="checkbox"/>
3) Senior official (e.g. inspector, senior police officer, fire service and prison officer, immigration officer, customs officer, surveyor, ...)	<input type="checkbox"/>	<input type="checkbox"/>
4) Store worker (e.g. sales representative, shop sales person, ...)	<input type="checkbox"/>	<input type="checkbox"/>
5) Skilled manual worker (someone who has specialist skills, e.g. plumber, electrician, fitter, foreman, bus driver or conductor, police constable, agricultural worker, chef/cook, ...)	<input type="checkbox"/>	<input type="checkbox"/>
6) Semi-skilled manual (a job requiring a small amount of training or experience to start, e.g. hairdresser, beautician, housekeeper, caretaker, childcare worker, ...)	<input type="checkbox"/>	<input type="checkbox"/>
7) Unskilled worker (general labourer, porter, casual worker, lorry driver, window cleaner, domestic cleaner, caterer, bar staff)	<input type="checkbox"/>	<input type="checkbox"/>
8) Homemaker (househusband or housewife)	<input type="checkbox"/>	<input type="checkbox"/>
9) Don't know	<input type="checkbox"/>	<input type="checkbox"/>
10) Unemployed	<input type="checkbox"/>	<input type="checkbox"/>

o) How many adults live in your home?

2. MORE ABOUT YOU

For each of the questions please tick **one** choice that best represents your response to each statement.

During school time, how often do you take part in the following activities **supervised** by adults?

	Not at all	Less than once a month	Once or twice a month	Once a week	More than once a week
a) Sports, e.g. football, karate, local gym	<input type="checkbox"/>	<input type="checkbox"/>	<input type="checkbox"/>	<input type="checkbox"/>	<input type="checkbox"/>
b) Arts and music	<input type="checkbox"/>	<input type="checkbox"/>	<input type="checkbox"/>	<input type="checkbox"/>	<input type="checkbox"/>
c) Religious activities, e.g. attending church or temple	<input type="checkbox"/>	<input type="checkbox"/>	<input type="checkbox"/>	<input type="checkbox"/>	<input type="checkbox"/>
d) Youth centres/clubs	<input type="checkbox"/>	<input type="checkbox"/>	<input type="checkbox"/>	<input type="checkbox"/>	<input type="checkbox"/>
e) Uniformed activities, e.g. cadets, scouts, guides	<input type="checkbox"/>	<input type="checkbox"/>	<input type="checkbox"/>	<input type="checkbox"/>	<input type="checkbox"/>

During school time, how often do you take part in the following activities that are **not** supervised by adults?

f) Sports, e.g. football	<input type="checkbox"/>	<input type="checkbox"/>	<input type="checkbox"/>	<input type="checkbox"/>	<input type="checkbox"/>
g) Arts and music	<input type="checkbox"/>	<input type="checkbox"/>	<input type="checkbox"/>	<input type="checkbox"/>	<input type="checkbox"/>
h) Youth centres/clubs	<input type="checkbox"/>	<input type="checkbox"/>	<input type="checkbox"/>	<input type="checkbox"/>	<input type="checkbox"/>
i) Computers, e.g. MSN, Facebook	<input type="checkbox"/>	<input type="checkbox"/>	<input type="checkbox"/>	<input type="checkbox"/>	<input type="checkbox"/>
j) Activities on your own, e.g. reading, writing, pets	<input type="checkbox"/>	<input type="checkbox"/>	<input type="checkbox"/>	<input type="checkbox"/>	<input type="checkbox"/>

How often do you take part in the following physics activities?

k) Physics clubs	<input type="checkbox"/>	<input type="checkbox"/>	<input type="checkbox"/>	<input type="checkbox"/>	<input type="checkbox"/>
l) Physics Master classes	<input type="checkbox"/>	<input type="checkbox"/>	<input type="checkbox"/>	<input type="checkbox"/>	<input type="checkbox"/>
m) Physics competitions	<input type="checkbox"/>	<input type="checkbox"/>	<input type="checkbox"/>	<input type="checkbox"/>	<input type="checkbox"/>
n) Physics-related outings with your family	<input type="checkbox"/>	<input type="checkbox"/>	<input type="checkbox"/>	<input type="checkbox"/>	<input type="checkbox"/>
o) Physics-related outings with your school	<input type="checkbox"/>	<input type="checkbox"/>	<input type="checkbox"/>	<input type="checkbox"/>	<input type="checkbox"/>

3. YOUR FUTURE STUDIES

YES

NO

a) I am going to continue with my studies after the age of 16.

If **yes** then please go straight to question c.

If **no**, please say **why** in part b below (then go to section 4):

b) I am NOT going to continue with my studies after the age of 16 because:

c) What are the subjects that you are **most likely** to take **after** your GCSEs? Please write them down in order of your preference:

1. _____ because

2. _____ because

3. _____ because

4. _____ because

4. ABOUT STUDYING PHYSICS

	Strongly Agree	Agree	Slightly Agree	Slightly Disagree	Disagree	Strongly Disagree	Can't Say
a) I intend to continue to study physics after my GCSEs.	<input type="checkbox"/>	<input type="checkbox"/>	<input type="checkbox"/>	<input type="checkbox"/>	<input type="checkbox"/>	<input type="checkbox"/>	
b) I think physics is a useful subject.	<input type="checkbox"/>	<input type="checkbox"/>	<input type="checkbox"/>	<input type="checkbox"/>	<input type="checkbox"/>	<input type="checkbox"/>	
c) I think physics is an interesting subject.	<input type="checkbox"/>	<input type="checkbox"/>	<input type="checkbox"/>	<input type="checkbox"/>	<input type="checkbox"/>	<input type="checkbox"/>	
d) I think physics will help me in the job I want to do in the future.	<input type="checkbox"/>	<input type="checkbox"/>	<input type="checkbox"/>	<input type="checkbox"/>	<input type="checkbox"/>	<input type="checkbox"/>	
e) My friends are going to study physics after their GCSEs.	<input type="checkbox"/>	<input type="checkbox"/>	<input type="checkbox"/>	<input type="checkbox"/>	<input type="checkbox"/>	<input type="checkbox"/>	<input type="checkbox"/>
f) I am good at physics.	<input type="checkbox"/>	<input type="checkbox"/>	<input type="checkbox"/>	<input type="checkbox"/>	<input type="checkbox"/>	<input type="checkbox"/>	
g) My teacher thinks that I should continue with physics beyond my GCSEs.	<input type="checkbox"/>	<input type="checkbox"/>	<input type="checkbox"/>	<input type="checkbox"/>	<input type="checkbox"/>	<input type="checkbox"/>	<input type="checkbox"/>
h) My friends think that I should continue with physics after my GCSEs	<input type="checkbox"/>	<input type="checkbox"/>	<input type="checkbox"/>	<input type="checkbox"/>	<input type="checkbox"/>	<input type="checkbox"/>	<input type="checkbox"/>
i) I have been advised by someone else that physics is a good subject to study after my GCSEs.	<input type="checkbox"/>	<input type="checkbox"/>	<input type="checkbox"/>	<input type="checkbox"/>	<input type="checkbox"/>	<input type="checkbox"/>	

5. YOUR VIEWS ON PHYSICS

Please tell us what you think **science** is about:

Please tell us what you think **physics** is about:

	Strongly Agree	Agree	Slightly Agree	Slightly Disagree	Disagree	Strongly Disagree	Can't Say
a) People who are good at physics get well-paid jobs.	<input type="checkbox"/>	<input type="checkbox"/>	<input type="checkbox"/>	<input type="checkbox"/>	<input type="checkbox"/>	<input type="checkbox"/>	<input type="checkbox"/>
b) Being good at physics impresses people.	<input type="checkbox"/>	<input type="checkbox"/>	<input type="checkbox"/>	<input type="checkbox"/>	<input type="checkbox"/>	<input type="checkbox"/>	<input type="checkbox"/>
c) Physics teaches you to think logically.	<input type="checkbox"/>	<input type="checkbox"/>	<input type="checkbox"/>	<input type="checkbox"/>	<input type="checkbox"/>	<input type="checkbox"/>	<input type="checkbox"/>
d) Physics helps you in solving everyday problems.	<input type="checkbox"/>	<input type="checkbox"/>	<input type="checkbox"/>	<input type="checkbox"/>	<input type="checkbox"/>	<input type="checkbox"/>	<input type="checkbox"/>
e) Physics improves your social skills.	<input type="checkbox"/>	<input type="checkbox"/>	<input type="checkbox"/>	<input type="checkbox"/>	<input type="checkbox"/>	<input type="checkbox"/>	<input type="checkbox"/>
f) To be good at physics, you need to be creative.	<input type="checkbox"/>	<input type="checkbox"/>	<input type="checkbox"/>	<input type="checkbox"/>	<input type="checkbox"/>	<input type="checkbox"/>	<input type="checkbox"/>
g) To be good at physics, you need to work hard.	<input type="checkbox"/>	<input type="checkbox"/>	<input type="checkbox"/>	<input type="checkbox"/>	<input type="checkbox"/>	<input type="checkbox"/>	<input type="checkbox"/>
h) Being good at physics makes you popular.	<input type="checkbox"/>	<input type="checkbox"/>	<input type="checkbox"/>	<input type="checkbox"/>	<input type="checkbox"/>	<input type="checkbox"/>	<input type="checkbox"/>
i) Physics is interesting.	<input type="checkbox"/>	<input type="checkbox"/>	<input type="checkbox"/>	<input type="checkbox"/>	<input type="checkbox"/>	<input type="checkbox"/>	<input type="checkbox"/>
j) Physics is important in making new discoveries.	<input type="checkbox"/>	<input type="checkbox"/>	<input type="checkbox"/>	<input type="checkbox"/>	<input type="checkbox"/>	<input type="checkbox"/>	<input type="checkbox"/>
k) Those who are good at physics are clever.	<input type="checkbox"/>	<input type="checkbox"/>	<input type="checkbox"/>	<input type="checkbox"/>	<input type="checkbox"/>	<input type="checkbox"/>	<input type="checkbox"/>
l) These days, everybody needs to know some physics.	<input type="checkbox"/>	<input type="checkbox"/>	<input type="checkbox"/>	<input type="checkbox"/>	<input type="checkbox"/>	<input type="checkbox"/>	<input type="checkbox"/>
m) In physics, it is interesting to find out about the laws that explain different phenomena.	<input type="checkbox"/>	<input type="checkbox"/>	<input type="checkbox"/>	<input type="checkbox"/>	<input type="checkbox"/>	<input type="checkbox"/>	<input type="checkbox"/>
n) There is only one right way to solve any physics problem.	<input type="checkbox"/>	<input type="checkbox"/>	<input type="checkbox"/>	<input type="checkbox"/>	<input type="checkbox"/>	<input type="checkbox"/>	<input type="checkbox"/>
x) Can you think of any experiences, such as a book you read, a film you saw, a place you visited or a person you met or know, that may have changed the way you view physics? If yes, please explain:							

6. YOUR PHYSICS LESSONS

	Strongly Agree	Agree	Slightly Agree	Slightly Disagree	Disagree	Strongly Disagree
a) I look forward to physics classes.	<input type="checkbox"/>	<input type="checkbox"/>	<input type="checkbox"/>	<input type="checkbox"/>	<input type="checkbox"/>	<input type="checkbox"/>
b) In my physics lessons, my teacher explains how a physics idea can be applied to a number of different situations.	<input type="checkbox"/>	<input type="checkbox"/>	<input type="checkbox"/>	<input type="checkbox"/>	<input type="checkbox"/>	<input type="checkbox"/>
c) In my physics lessons, I have the opportunity to discuss my ideas about physics.	<input type="checkbox"/>	<input type="checkbox"/>	<input type="checkbox"/>	<input type="checkbox"/>	<input type="checkbox"/>	<input type="checkbox"/>
d) I do well in physics tests.	<input type="checkbox"/>	<input type="checkbox"/>	<input type="checkbox"/>	<input type="checkbox"/>	<input type="checkbox"/>	<input type="checkbox"/>
e) I enjoy my physics lessons.	<input type="checkbox"/>	<input type="checkbox"/>	<input type="checkbox"/>	<input type="checkbox"/>	<input type="checkbox"/>	<input type="checkbox"/>
f) I can see the relevance of physics lessons.	<input type="checkbox"/>	<input type="checkbox"/>	<input type="checkbox"/>	<input type="checkbox"/>	<input type="checkbox"/>	<input type="checkbox"/>
g) I find it difficult to apply most physics concepts to everyday problems.	<input type="checkbox"/>	<input type="checkbox"/>	<input type="checkbox"/>	<input type="checkbox"/>	<input type="checkbox"/>	<input type="checkbox"/>
h) When I am doing physics, I always know what I am doing.	<input type="checkbox"/>	<input type="checkbox"/>	<input type="checkbox"/>	<input type="checkbox"/>	<input type="checkbox"/>	<input type="checkbox"/>
i) When I am doing physics, I am learning new skills.	<input type="checkbox"/>	<input type="checkbox"/>	<input type="checkbox"/>	<input type="checkbox"/>	<input type="checkbox"/>	<input type="checkbox"/>
j) When I am doing physics, I am bored.	<input type="checkbox"/>	<input type="checkbox"/>	<input type="checkbox"/>	<input type="checkbox"/>	<input type="checkbox"/>	<input type="checkbox"/>
k) When I am doing physics, I pay attention.	<input type="checkbox"/>	<input type="checkbox"/>	<input type="checkbox"/>	<input type="checkbox"/>	<input type="checkbox"/>	<input type="checkbox"/>
l) When I am doing physics, I get upset.	<input type="checkbox"/>	<input type="checkbox"/>	<input type="checkbox"/>	<input type="checkbox"/>	<input type="checkbox"/>	<input type="checkbox"/>
m) When I am doing physics, I daydream.	<input type="checkbox"/>	<input type="checkbox"/>	<input type="checkbox"/>	<input type="checkbox"/>	<input type="checkbox"/>	<input type="checkbox"/>
n) I like my physics teacher.	<input type="checkbox"/>	<input type="checkbox"/>	<input type="checkbox"/>	<input type="checkbox"/>	<input type="checkbox"/>	<input type="checkbox"/>
o) In my physics lessons, we are given the opportunity to do an investigation to test our own ideas.	<input type="checkbox"/>	<input type="checkbox"/>	<input type="checkbox"/>	<input type="checkbox"/>	<input type="checkbox"/>	<input type="checkbox"/>
p) I look forward to spending time in the laboratory doing practical investigations.	<input type="checkbox"/>	<input type="checkbox"/>	<input type="checkbox"/>	<input type="checkbox"/>	<input type="checkbox"/>	<input type="checkbox"/>

	Near top	A bit above average	Average	A bit below average	Near bottom
x) Thinking about your physics lessons, how do you feel you compare with the others in your group?	<input type="checkbox"/>	<input type="checkbox"/>	<input type="checkbox"/>	<input type="checkbox"/>	<input type="checkbox"/>

7. YOUR PHYSICS TEACHER

	Strongly Agree	Agree	Slightly Agree	Slightly Disagree	Disagree	Strongly Disagree	Can't Say
a) My physics teacher has high expectations of what the students can learn.	<input type="checkbox"/>	<input type="checkbox"/>	<input type="checkbox"/>	<input type="checkbox"/>	<input type="checkbox"/>	<input type="checkbox"/>	<input type="checkbox"/>
b) My physics teacher believes that all students can learn physics.	<input type="checkbox"/>	<input type="checkbox"/>	<input type="checkbox"/>	<input type="checkbox"/>	<input type="checkbox"/>	<input type="checkbox"/>	<input type="checkbox"/>
c) My physics teacher wants us to really understand physics.	<input type="checkbox"/>	<input type="checkbox"/>	<input type="checkbox"/>	<input type="checkbox"/>	<input type="checkbox"/>	<input type="checkbox"/>	<input type="checkbox"/>
d) My physics teacher sets us homework.	<input type="checkbox"/>	<input type="checkbox"/>	<input type="checkbox"/>	<input type="checkbox"/>	<input type="checkbox"/>	<input type="checkbox"/>	<input type="checkbox"/>
e) My physics teacher believes that mistakes are OK as long as we are learning.	<input type="checkbox"/>	<input type="checkbox"/>	<input type="checkbox"/>	<input type="checkbox"/>	<input type="checkbox"/>	<input type="checkbox"/>	<input type="checkbox"/>
f) My physics teacher is interested in me as a person.	<input type="checkbox"/>	<input type="checkbox"/>	<input type="checkbox"/>	<input type="checkbox"/>	<input type="checkbox"/>	<input type="checkbox"/>	<input type="checkbox"/>
g) My physics teacher seems to like all the students.	<input type="checkbox"/>	<input type="checkbox"/>	<input type="checkbox"/>	<input type="checkbox"/>	<input type="checkbox"/>	<input type="checkbox"/>	<input type="checkbox"/>
h) My physics teacher is interested in what the students think.	<input type="checkbox"/>	<input type="checkbox"/>	<input type="checkbox"/>	<input type="checkbox"/>	<input type="checkbox"/>	<input type="checkbox"/>	<input type="checkbox"/>
i) My physics teacher only cares about students who get good marks in physics.	<input type="checkbox"/>	<input type="checkbox"/>	<input type="checkbox"/>	<input type="checkbox"/>	<input type="checkbox"/>	<input type="checkbox"/>	<input type="checkbox"/>
j) My physics teacher lets us get away with not doing our homework.	<input type="checkbox"/>	<input type="checkbox"/>	<input type="checkbox"/>	<input type="checkbox"/>	<input type="checkbox"/>	<input type="checkbox"/>	<input type="checkbox"/>
k) My physics teacher treats all students the same regardless of their physics ability.	<input type="checkbox"/>	<input type="checkbox"/>	<input type="checkbox"/>	<input type="checkbox"/>	<input type="checkbox"/>	<input type="checkbox"/>	<input type="checkbox"/>
l) My physics teacher is good at explaining physics.	<input type="checkbox"/>	<input type="checkbox"/>	<input type="checkbox"/>	<input type="checkbox"/>	<input type="checkbox"/>	<input type="checkbox"/>	<input type="checkbox"/>
m) My physics teacher marks and returns homework quickly.	<input type="checkbox"/>	<input type="checkbox"/>	<input type="checkbox"/>	<input type="checkbox"/>	<input type="checkbox"/>	<input type="checkbox"/>	<input type="checkbox"/>

8. HELP WITH PHYSICS

a) I need help with physics	<input type="checkbox"/>	<input type="checkbox"/>	<input type="checkbox"/>	<input type="checkbox"/>	<input type="checkbox"/>	<input type="checkbox"/>
b) I do extra physics at home (i.e. work not set by teachers).	<input type="checkbox"/>	<input type="checkbox"/>	<input type="checkbox"/>	<input type="checkbox"/>	<input type="checkbox"/>	<input type="checkbox"/>
c) I think ICT is very useful in helping me learn physics.	<input type="checkbox"/>	<input type="checkbox"/>	<input type="checkbox"/>	<input type="checkbox"/>	<input type="checkbox"/>	<input type="checkbox"/>
d) I use physics programmes on my computer to help me with my physics, e.g. podcasts, BBC Bite size, games etc.	<input type="checkbox"/>	<input type="checkbox"/>	<input type="checkbox"/>	<input type="checkbox"/>	<input type="checkbox"/>	<input type="checkbox"/>
e) I use online groups to help me learn physics.	<input type="checkbox"/>	<input type="checkbox"/>	<input type="checkbox"/>	<input type="checkbox"/>	<input type="checkbox"/>	<input type="checkbox"/>
f) Do any of these people ever help you with your physics work:						
i) Someone in my family	<input type="checkbox"/>	<input type="checkbox"/>	<input type="checkbox"/>	<input type="checkbox"/>	<input type="checkbox"/>	<input type="checkbox"/>
ii) My friend(s)	<input type="checkbox"/>	<input type="checkbox"/>	<input type="checkbox"/>	<input type="checkbox"/>	<input type="checkbox"/>	<input type="checkbox"/>
iii) A private tutor	<input type="checkbox"/>	<input type="checkbox"/>	<input type="checkbox"/>	<input type="checkbox"/>	<input type="checkbox"/>	<input type="checkbox"/>
iv) My physics teacher	<input type="checkbox"/>	<input type="checkbox"/>	<input type="checkbox"/>	<input type="checkbox"/>	<input type="checkbox"/>	<input type="checkbox"/>
v) Someone else not listed above	<input type="checkbox"/>	<input type="checkbox"/>	<input type="checkbox"/>	<input type="checkbox"/>	<input type="checkbox"/>	<input type="checkbox"/>

9. MORE ABOUT YOU

	Strongly Agree	Agree	Slightly Agree	Slightly Disagree	Disagree	Strongly Disagree
a) I enjoy strategy games (e.g. Chess, battleships, Sudoku)	<input type="checkbox"/>	<input type="checkbox"/>	<input type="checkbox"/>	<input type="checkbox"/>	<input type="checkbox"/>	<input type="checkbox"/>
b) I like to read (e.g. interesting books or magazines).	<input type="checkbox"/>	<input type="checkbox"/>	<input type="checkbox"/>	<input type="checkbox"/>	<input type="checkbox"/>	<input type="checkbox"/>
c) I am fascinated by how machines work.	<input type="checkbox"/>	<input type="checkbox"/>	<input type="checkbox"/>	<input type="checkbox"/>	<input type="checkbox"/>	<input type="checkbox"/>
d) I find it difficult to read and understand maps.	<input type="checkbox"/>	<input type="checkbox"/>	<input type="checkbox"/>	<input type="checkbox"/>	<input type="checkbox"/>	<input type="checkbox"/>
e) I have <i>organised</i> collections (e.g. music files, photos, Pokemon cards).	<input type="checkbox"/>	<input type="checkbox"/>	<input type="checkbox"/>	<input type="checkbox"/>	<input type="checkbox"/>	<input type="checkbox"/>
f) I think memorising dates is important in learning about history.	<input type="checkbox"/>	<input type="checkbox"/>	<input type="checkbox"/>	<input type="checkbox"/>	<input type="checkbox"/>	<input type="checkbox"/>
g) What I like about learning a foreign language is the way I can learn the grammar by following a pattern.	<input type="checkbox"/>	<input type="checkbox"/>	<input type="checkbox"/>	<input type="checkbox"/>	<input type="checkbox"/>	<input type="checkbox"/>
h) I use my mobile to access the internet for information and/or email.	<input type="checkbox"/>	<input type="checkbox"/>	<input type="checkbox"/>	<input type="checkbox"/>	<input type="checkbox"/>	<input type="checkbox"/>
i) I like to interact with people online.	<input type="checkbox"/>	<input type="checkbox"/>	<input type="checkbox"/>	<input type="checkbox"/>	<input type="checkbox"/>	<input type="checkbox"/>
j) I upload digital pictures and videos on to internet sites such as Facebook, Flickr, Youtube or Bebo.	<input type="checkbox"/>	<input type="checkbox"/>	<input type="checkbox"/>	<input type="checkbox"/>	<input type="checkbox"/>	<input type="checkbox"/>
k) I like to find the reasons for things.	<input type="checkbox"/>	<input type="checkbox"/>	<input type="checkbox"/>	<input type="checkbox"/>	<input type="checkbox"/>	<input type="checkbox"/>
l) I like to solve problems.	<input type="checkbox"/>	<input type="checkbox"/>	<input type="checkbox"/>	<input type="checkbox"/>	<input type="checkbox"/>	<input type="checkbox"/>
m) I watch science documentaries on television and/or read about science	<input type="checkbox"/>	<input type="checkbox"/>	<input type="checkbox"/>	<input type="checkbox"/>	<input type="checkbox"/>	<input type="checkbox"/>

10. YOUR SCHOOL

a) It is important for me to know how well I am doing at school.	<input type="checkbox"/>	<input type="checkbox"/>	<input type="checkbox"/>	<input type="checkbox"/>	<input type="checkbox"/>	<input type="checkbox"/>
b) I prefer school tasks that really make me think.	<input type="checkbox"/>	<input type="checkbox"/>	<input type="checkbox"/>	<input type="checkbox"/>	<input type="checkbox"/>	<input type="checkbox"/>
c) I like work that I learn from, even if I make a lot of mistakes.	<input type="checkbox"/>	<input type="checkbox"/>	<input type="checkbox"/>	<input type="checkbox"/>	<input type="checkbox"/>	<input type="checkbox"/>
d) This school will help me be successful.	<input type="checkbox"/>	<input type="checkbox"/>	<input type="checkbox"/>	<input type="checkbox"/>	<input type="checkbox"/>	<input type="checkbox"/>
e) Adults in this school seem to listen to students' concerns.	<input type="checkbox"/>	<input type="checkbox"/>	<input type="checkbox"/>	<input type="checkbox"/>	<input type="checkbox"/>	<input type="checkbox"/>
f) I can be myself at this school.	<input type="checkbox"/>	<input type="checkbox"/>	<input type="checkbox"/>	<input type="checkbox"/>	<input type="checkbox"/>	<input type="checkbox"/>
g) I feel like I belong at this school.	<input type="checkbox"/>	<input type="checkbox"/>	<input type="checkbox"/>	<input type="checkbox"/>	<input type="checkbox"/>	<input type="checkbox"/>
h) I am comfortable talking to teachers about problems in this school.	<input type="checkbox"/>	<input type="checkbox"/>	<input type="checkbox"/>	<input type="checkbox"/>	<input type="checkbox"/>	<input type="checkbox"/>
i) Students of all backgrounds are respected at my school.	<input type="checkbox"/>	<input type="checkbox"/>	<input type="checkbox"/>	<input type="checkbox"/>	<input type="checkbox"/>	<input type="checkbox"/>

11. YOUR FAMILY'S VIEWS

	Strongly Agree	Agree	Slightly Agree	Slightly Disagree	Disagree	Strongly Disagree	Can't Say
a) My parents/carers understand me.	<input type="checkbox"/>	<input type="checkbox"/>	<input type="checkbox"/>	<input type="checkbox"/>	<input type="checkbox"/>	<input type="checkbox"/>	<input type="checkbox"/>
b) I get along well with my parents/carers.	<input type="checkbox"/>	<input type="checkbox"/>	<input type="checkbox"/>	<input type="checkbox"/>	<input type="checkbox"/>	<input type="checkbox"/>	<input type="checkbox"/>
c) I prefer not to talk to my parents/carers about issues that concern me.	<input type="checkbox"/>	<input type="checkbox"/>	<input type="checkbox"/>	<input type="checkbox"/>	<input type="checkbox"/>	<input type="checkbox"/>	<input type="checkbox"/>
d) My parents/carers are disappointed with what I do.	<input type="checkbox"/>	<input type="checkbox"/>	<input type="checkbox"/>	<input type="checkbox"/>	<input type="checkbox"/>	<input type="checkbox"/>	<input type="checkbox"/>
e) Someone in my family:							
i) wants me to work hard and try to the best of my ability.	<input type="checkbox"/>	<input type="checkbox"/>	<input type="checkbox"/>	<input type="checkbox"/>	<input type="checkbox"/>	<input type="checkbox"/>	<input type="checkbox"/>
ii) wants me to be successful in the subjects that I am interested in.	<input type="checkbox"/>	<input type="checkbox"/>	<input type="checkbox"/>	<input type="checkbox"/>	<input type="checkbox"/>	<input type="checkbox"/>	<input type="checkbox"/>
iii) wants me to do well in order to a good job.	<input type="checkbox"/>	<input type="checkbox"/>	<input type="checkbox"/>	<input type="checkbox"/>	<input type="checkbox"/>	<input type="checkbox"/>	<input type="checkbox"/>
iv) wants me to be successful at school in physics.	<input type="checkbox"/>	<input type="checkbox"/>	<input type="checkbox"/>	<input type="checkbox"/>	<input type="checkbox"/>	<input type="checkbox"/>	<input type="checkbox"/>
v) wants me to be the best in my class in physics.	<input type="checkbox"/>	<input type="checkbox"/>	<input type="checkbox"/>	<input type="checkbox"/>	<input type="checkbox"/>	<input type="checkbox"/>	<input type="checkbox"/>
vi) wants me to talk to them about my physics work.	<input type="checkbox"/>	<input type="checkbox"/>	<input type="checkbox"/>	<input type="checkbox"/>	<input type="checkbox"/>	<input type="checkbox"/>	<input type="checkbox"/>
vii) thinks that you have to be born with physics talent to do well at it.	<input type="checkbox"/>	<input type="checkbox"/>	<input type="checkbox"/>	<input type="checkbox"/>	<input type="checkbox"/>	<input type="checkbox"/>	<input type="checkbox"/>
viii) thinks that I should continue with physics after my GCSEs.	<input type="checkbox"/>	<input type="checkbox"/>	<input type="checkbox"/>	<input type="checkbox"/>	<input type="checkbox"/>	<input type="checkbox"/>	<input type="checkbox"/>
ix) thinks that anyone can do physics if they try hard enough.	<input type="checkbox"/>	<input type="checkbox"/>	<input type="checkbox"/>	<input type="checkbox"/>	<input type="checkbox"/>	<input type="checkbox"/>	<input type="checkbox"/>
f) If my general standard of physics work slipped, my family would:							
i) take away privileges or ground me.	<input type="checkbox"/>	<input type="checkbox"/>	<input type="checkbox"/>	<input type="checkbox"/>	<input type="checkbox"/>	<input type="checkbox"/>	<input type="checkbox"/>
ii) threaten to punish me.	<input type="checkbox"/>	<input type="checkbox"/>	<input type="checkbox"/>	<input type="checkbox"/>	<input type="checkbox"/>	<input type="checkbox"/>	<input type="checkbox"/>

12. OTHER PEOPLE AND YOU

a) I feel comfortable around people.	<input type="checkbox"/>	<input type="checkbox"/>	<input type="checkbox"/>	<input type="checkbox"/>	<input type="checkbox"/>	<input type="checkbox"/>
b) I don't like to draw attention to myself.	<input type="checkbox"/>	<input type="checkbox"/>	<input type="checkbox"/>	<input type="checkbox"/>	<input type="checkbox"/>	<input type="checkbox"/>
c) I start conversations easily.	<input type="checkbox"/>	<input type="checkbox"/>	<input type="checkbox"/>	<input type="checkbox"/>	<input type="checkbox"/>	<input type="checkbox"/>
d) I am quiet around strangers.	<input type="checkbox"/>	<input type="checkbox"/>	<input type="checkbox"/>	<input type="checkbox"/>	<input type="checkbox"/>	<input type="checkbox"/>
e) I don't mind being the centre of attention.	<input type="checkbox"/>	<input type="checkbox"/>	<input type="checkbox"/>	<input type="checkbox"/>	<input type="checkbox"/>	<input type="checkbox"/>
f) I like to keep in the background.	<input type="checkbox"/>	<input type="checkbox"/>	<input type="checkbox"/>	<input type="checkbox"/>	<input type="checkbox"/>	<input type="checkbox"/>
g) I talk to a lot of different people at parties.	<input type="checkbox"/>	<input type="checkbox"/>	<input type="checkbox"/>	<input type="checkbox"/>	<input type="checkbox"/>	<input type="checkbox"/>
h) I like to see the whole class do well on a test.	<input type="checkbox"/>	<input type="checkbox"/>	<input type="checkbox"/>	<input type="checkbox"/>	<input type="checkbox"/>	<input type="checkbox"/>

	Strongly Agree	Agree	Slightly Agree	Slightly Disagree	Disagree	Strongly Disagree
i) I try not to speak unkindly of others.	<input type="checkbox"/>	<input type="checkbox"/>	<input type="checkbox"/>	<input type="checkbox"/>	<input type="checkbox"/>	<input type="checkbox"/>
j) Teamwork is really more important than who wins.	<input type="checkbox"/>	<input type="checkbox"/>	<input type="checkbox"/>	<input type="checkbox"/>	<input type="checkbox"/>	<input type="checkbox"/>
k) I don't trust very many people.	<input type="checkbox"/>	<input type="checkbox"/>	<input type="checkbox"/>	<input type="checkbox"/>	<input type="checkbox"/>	<input type="checkbox"/>
l) I want to be successful, even if it's at the expense of others.	<input type="checkbox"/>	<input type="checkbox"/>	<input type="checkbox"/>	<input type="checkbox"/>	<input type="checkbox"/>	<input type="checkbox"/>
m) A group slows me down.	<input type="checkbox"/>	<input type="checkbox"/>	<input type="checkbox"/>	<input type="checkbox"/>	<input type="checkbox"/>	<input type="checkbox"/>
n) I like to help others.	<input type="checkbox"/>	<input type="checkbox"/>	<input type="checkbox"/>	<input type="checkbox"/>	<input type="checkbox"/>	<input type="checkbox"/>
o) It is important to treat others with kindness.	<input type="checkbox"/>	<input type="checkbox"/>	<input type="checkbox"/>	<input type="checkbox"/>	<input type="checkbox"/>	<input type="checkbox"/>
p) I do not give anyone a second chance.	<input type="checkbox"/>	<input type="checkbox"/>	<input type="checkbox"/>	<input type="checkbox"/>	<input type="checkbox"/>	<input type="checkbox"/>

13. YOUR EVERYDAY LIFE

a) I like to think up new ideas.	<input type="checkbox"/>	<input type="checkbox"/>	<input type="checkbox"/>	<input type="checkbox"/>	<input type="checkbox"/>	<input type="checkbox"/>
b) I am interested in how others see the world.	<input type="checkbox"/>	<input type="checkbox"/>	<input type="checkbox"/>	<input type="checkbox"/>	<input type="checkbox"/>	<input type="checkbox"/>
c) How many friends I have depends on how nice a person I am.	<input type="checkbox"/>	<input type="checkbox"/>	<input type="checkbox"/>	<input type="checkbox"/>	<input type="checkbox"/>	<input type="checkbox"/>
d) When I make plans, I am almost certain to make them work.	<input type="checkbox"/>	<input type="checkbox"/>	<input type="checkbox"/>	<input type="checkbox"/>	<input type="checkbox"/>	<input type="checkbox"/>
e) When I get what I want, it's usually because I worked hard for it.	<input type="checkbox"/>	<input type="checkbox"/>	<input type="checkbox"/>	<input type="checkbox"/>	<input type="checkbox"/>	<input type="checkbox"/>
f) I can pretty much determine what will happen in my life.	<input type="checkbox"/>	<input type="checkbox"/>	<input type="checkbox"/>	<input type="checkbox"/>	<input type="checkbox"/>	<input type="checkbox"/>
g) I am sure of myself.	<input type="checkbox"/>	<input type="checkbox"/>	<input type="checkbox"/>	<input type="checkbox"/>	<input type="checkbox"/>	<input type="checkbox"/>
h) I am often depressed.	<input type="checkbox"/>	<input type="checkbox"/>	<input type="checkbox"/>	<input type="checkbox"/>	<input type="checkbox"/>	<input type="checkbox"/>
i) I get upset very easily.	<input type="checkbox"/>	<input type="checkbox"/>	<input type="checkbox"/>	<input type="checkbox"/>	<input type="checkbox"/>	<input type="checkbox"/>
j) I am a calm person.	<input type="checkbox"/>	<input type="checkbox"/>	<input type="checkbox"/>	<input type="checkbox"/>	<input type="checkbox"/>	<input type="checkbox"/>
k) I am usually relaxed.	<input type="checkbox"/>	<input type="checkbox"/>	<input type="checkbox"/>	<input type="checkbox"/>	<input type="checkbox"/>	<input type="checkbox"/>
l) I worry about a lot of things.	<input type="checkbox"/>	<input type="checkbox"/>	<input type="checkbox"/>	<input type="checkbox"/>	<input type="checkbox"/>	<input type="checkbox"/>
m) I am a nervous person.	<input type="checkbox"/>	<input type="checkbox"/>	<input type="checkbox"/>	<input type="checkbox"/>	<input type="checkbox"/>	<input type="checkbox"/>

14. PHYSICS TASKS

These tasks have nothing to do with your school marks and your answers will **not** be seen by your teachers or anyone else at your school. We simply would like to compare your answers to these task items with your attitudes to physics.

E1. ELECTRICITY 1

In this circuit below, the reading on ammeter A_1 is 0.4 amps.

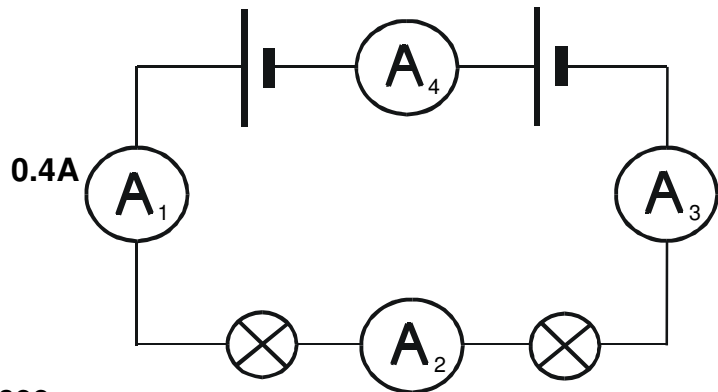

What reading you would expect to see

(a) .. on ammeter A_2 ?

(b) .. on ammeter A_3 ?

(c) .. on ammeter A_4 ?

Put a cross in ONE box

Put a cross in ONE box

Put a cross in ONE box

More than 0.4A

More than 0.4A

More than 0.4A

Exactly 0.4A

Exactly 0.4A

Exactly 0.4A

Less than 0.4A, but not zero

Less than 0.4A, but not zero

Less than 0.4A, but not zero

Zero

Zero

Zero

(d) Put a cross in ONE box below to explain your reason for choosing these answers.

- The current is the same all round the circuit.
- Each bulb uses up **some** of the current, leaving less for the next one.
- The first bulb uses up **all** of the current.
- The current is large close to the battery, and smaller further away.
- The reading is biggest where the currents from the two ends of the battery meet.

(e) How confident are you that your answers to question E1 are correct?

Very confident Fairly confident Not confident Just guessing

E2. ELECTRICITY 2

A bulb is connected to a battery.

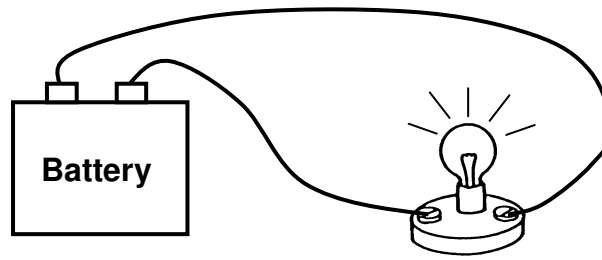

The bulb is lit.

(a) Which of the following best describes the **electric current** in this circuit?
Put a cross in **ONE** box only.

- There is an electric current through one wire to the bulb. It is **all** used up in the bulb. So there is **no current** in the other wire.

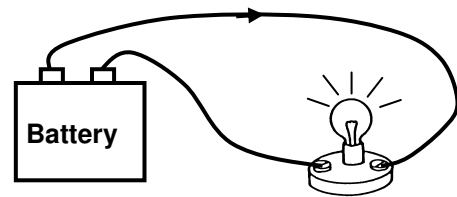

- There is an electric current through one wire to the bulb. **Some** of it is used up in the bulb. So there is a **smaller current** in the other wire.

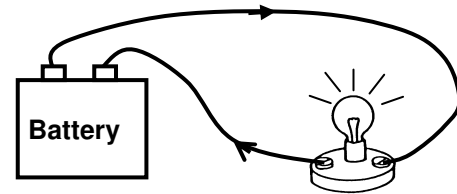

- There is an electric current through one wire to the bulb. It passes through the bulb and back to the battery. The current in the other wire is **the same size**.

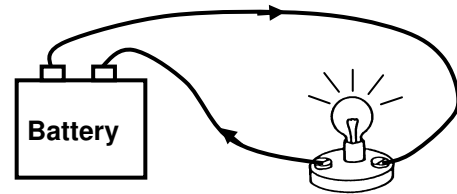

- There are **two** electric currents from the battery to the bulb. They **meet** at the bulb and this is what makes it light.

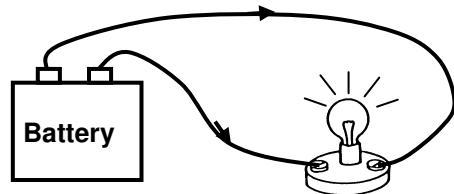

(b) How confident are you that your answer to **part (a)** is correct?

Very confident Fairly confident Not confident Just guessing

E3. How much do you agree with the following statements?

I find doing 'electricity' problems:

a) Enjoyable

b) Easy

c) Interesting

	Strongly Agree	Agree	Slightly Agree	Slightly Disagree	Disagree	Strongly Disagree
a) Enjoyable	<input type="checkbox"/>	<input type="checkbox"/>	<input type="checkbox"/>	<input type="checkbox"/>	<input type="checkbox"/>	<input type="checkbox"/>
b) Easy	<input type="checkbox"/>	<input type="checkbox"/>	<input type="checkbox"/>	<input type="checkbox"/>	<input type="checkbox"/>	<input type="checkbox"/>
c) Interesting	<input type="checkbox"/>	<input type="checkbox"/>	<input type="checkbox"/>	<input type="checkbox"/>	<input type="checkbox"/>	<input type="checkbox"/>

F1. FORCES 1

- highest point

Kim throws a tennis ball straight up into the air. It goes up and comes back down into her hand.

Think about the moment when the ball is at A, **on the way up** to its highest point.

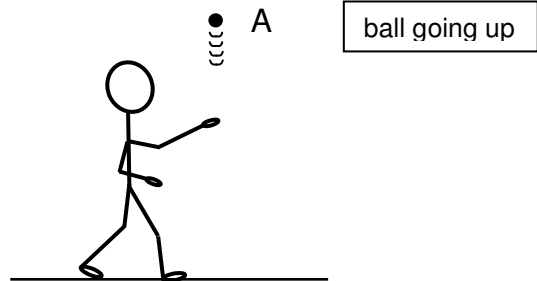

(a) How would you describe the motion of the ball at this instant?

Put a cross in ONE box only

- It is getting faster.
- It is moving at a steady speed.
- It is slowing down.

(b) Which of the following diagrams best shows the **vertical** forces on the ball when it is **at point A on the way up**?

(The length of the arrow indicates the size of each force.)

Put a cross in ONE box only

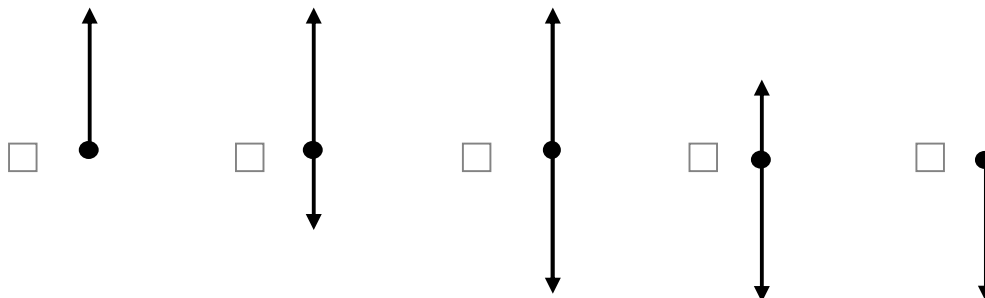

(c) Which of the following best describes the forces acting on the ball when it is **at point A on the way up?**

Put a cross in ONE box only

- The only force acting on the ball is the upward force of the throw.
- The only force acting on the ball is the downward force of gravity.
- The forces acting on the ball are the force of gravity, and the air resistance.
- The forces acting on the ball are the force of gravity, the air resistance, and the force of the throw.
- There are no forces acting on the ball.

(d) Which of the following diagrams best shows the **total force** acting on the ball when it is **at point A on the way up?**

- highest point

Put a cross in ONE box only

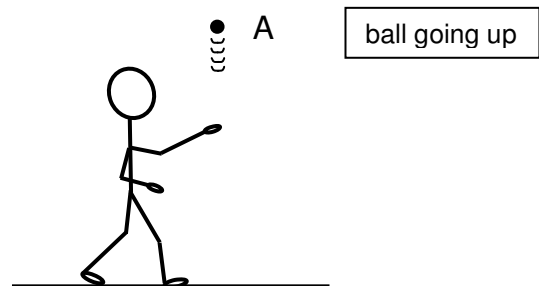
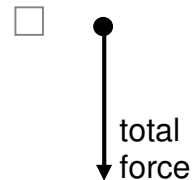
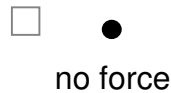
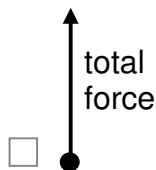

(e) How confident are you that your answers to this question (F1) are correct?

- Very confident Fairly confident Not confident Just guessing

F2. FORCES 2

Kim throws a tennis ball straight up into the air for a short distance and catches it when it comes down again.

- (a) In the diagrams below, the ball is **on the way up**. Which diagram best shows the **total force** on the ball? *Put a circle round one letter (A, B, or C) to show your answer.*

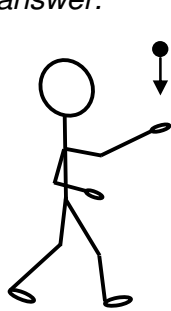

A

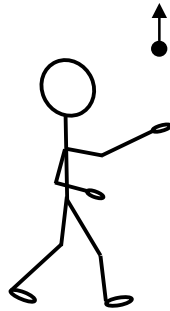

B

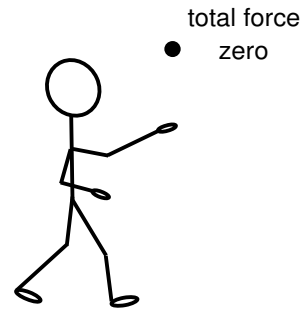

C

- (b) In the diagrams below, the ball is **right at the top of its flight**. Which diagram best shows the **total force** on the ball? *Put a circle round one letter (D, E or F) to show your answer.*

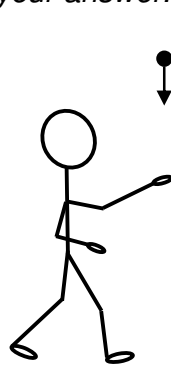

D

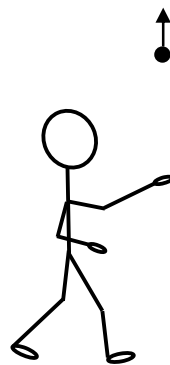

E

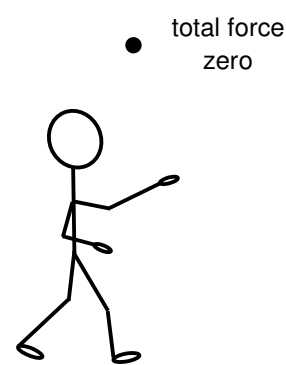

F

- (c) In the diagrams below, the ball is **on the way down**. Which diagram best shows the **total force** on the ball? *Put a circle round one letter (G, H or I) to show your answer.*

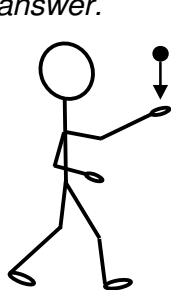

G

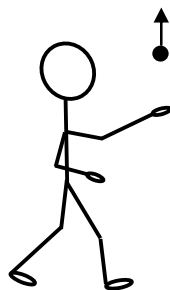

H

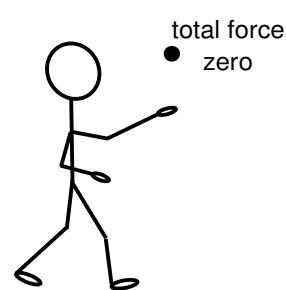

I

(d) Please explain your answers in the space below:

(e) How confident are you that your answers to this question (F2) are correct?

Very confident Fairly confident Not confident Just guessing

F3. How much do you agree with the following statements?

	<i>Strongly Agree</i>	<i>Agree</i>	<i>Slightly Agree</i>	<i>Slightly Disagree</i>	<i>Disagree</i>	<i>Strongly Disagree</i>
I find doing 'forces' problems:						
a) Enjoyable	<input type="checkbox"/>	<input type="checkbox"/>	<input type="checkbox"/>	<input type="checkbox"/>	<input type="checkbox"/>	<input type="checkbox"/>
b) Easy	<input type="checkbox"/>	<input type="checkbox"/>	<input type="checkbox"/>	<input type="checkbox"/>	<input type="checkbox"/>	<input type="checkbox"/>
c) Interesting	<input type="checkbox"/>	<input type="checkbox"/>	<input type="checkbox"/>	<input type="checkbox"/>	<input type="checkbox"/>	<input type="checkbox"/>

Please note the time that you finished this questionnaire:

Thank You