

Agreement and clitic restrictions in Basque

Karlos Arregi and Andrew Nevins

1. Introduction

The φ -features of ergative, absolutive, and dative arguments interact in various ways in the clitic and agreement system of the Basque finite auxiliary. In this paper, we discuss the syntax and morphology of agreement realization in a detailed study of the Bizkaian variety of Zamudio. Our main objective is to argue that the proper treatment of Basque verbal morphology must take into account both syntactic and postsyntactic principles and operations. That is, neither a strictly syntactic nor a strictly morphological account does justice to the clitic combination and agreement restriction effects. Rather, as certain processes refer to hierarchical structure and doubly-filled projections, and others refer to locality constraints on agreement at a distance, yet others refer to linear edge properties of morphophonological sensitivity and deletion of featural combinations, the division of labor for building and realizing the agreement morphology must be distributed, as delineated in the framework of Distributed Morphology (Halle and Marantz 1993, 1994, and much subsequent work).

Crucial to the discussion will be the claim that, contrary to the dominant viewpoint in the literature, the morphemes attached to the auxiliary that are often identified as agreement are actually clitics that double the ergative, absolutive, and dative arguments. Such a view is supported by the reanalysis it enables for the Person Case Constraint (PCC) in Basque, as well as providing a principled account for the distribution of plural enclisis. Importantly, however, we argue that the auxiliary does not manifest a single instance of syntactic Agree, with the absolutive argument. We show that this Agree operation may be subject to defective intervention in the context of dative arguments, leading to lack of agreement. The resulting model illustrates a dissociation in the effects of dative arguments on absolutive encoding, with distinct mechanisms for competition in clitic positions and locality-based agreement intervention.

Previous work on Basque verbal morphology addressing these issues in the generative framework typically does not concentrate on any local varieties of the language (though see Rezac 2006). However, we believe that sig-

nificant progress can be made in understanding the division of labor between syntactic and postsyntactic operations by looking at specific dialects thoroughly. Except when otherwise noted, all the data reported here are from Zamudio, and most of it has been taken from Gaminde (2000), a detailed descriptive grammar of this variety.¹

This paper is organized as follows. Sections 2 and 3 lay out some background on the theoretical model, and on basic clause structure in Basque, respectively. Section 4 introduces our basic claim about the clitic system of Basque and the constraints on clitic placement, offering a new account of the Person Case Constraint in Basque, while Section 5 is devoted to the morphophonological realization of clitics. In Section 6, we turn to bona fide agreement between T and the absolutive argument, and demonstrate the effects of dative intervention on this Agree relation. The paper ends with a general summary in section 7.

2. Background: Division of labor within the grammar

The general model of grammatical computation assumed here is one in which syntactic operations put together phrases and heads, and in which agreement involves copying of abstract morphosyntactic features with no phonological content. We assume the model of Chomsky (2000), in which the *Agree* operation establishes a syntactic relation between a functional category (a *Probe*) and a category within its c-command domain (the *Goal*). Importantly, the Agree relation respects syntactic locality, and no Probe-Goal relation may be established with a DP if a higher DP intervenes between the Probe and the Goal.

After syntactic operations are complete, phonological content is inserted for morphosyntactic features at PF, terminal by terminal. In this paper, we employ several syntactic and postsyntactic operations. Implicit throughout is the assumption that the former always precede the latter. This follows from the Distributed Morphology model that we adopt, in which postsyntactic operations apply in a module called *Morphological Structure* (MS).

In turn, MS itself contains several modules that follow a fixed derivational order. All the postsyntactic rules proposed here belong to one of these modules. They operate on the abstract terminal nodes of syntax, enacting either feature deletion (*Impoverishment*), *Fusion* of two terminals into one position of exponence, and/or reversal of the linear order of terminals (*Metathesis*). After all these operations apply, Vocabulary Insertion assigns phonological exponents to the terminal nodes, and readjustment rules modify

these phonological exponents in specific ways. We will discuss each of these operations as they become relevant throughout the paper.

The basic currency of agreement relations and Impoverishment operations are abstract morphosyntactic features. We provide the inventory of features that are relevant for this paper below.

- (1) *Person* (Halle 1997)
 - a. [+Author, +Participant] = first person
 - b. [-Author, +Participant] = second person
 - c. [-Author, -Participant] = third person
 - d. [+Author, -Participant] = logically impossible

- (2) *Case* (Calabrese 2008)
 - a. [+Motion, -Peripheral] = ergative
 - b. [+Motion, +Peripheral] = dative
 - c. [-Motion, -Peripheral] = absolutive

Vocabulary Insertion is a process of inserting a *vocabulary item* (i.e. an exponent) that realizes phonologically a set of syntactic features present at a particular syntactic terminal node. The *Subset Principle* governs the selection of an exponent to realize a particular set of features at a node, as stated in (3) (adapted from Halle (1997)).

- (3) A phonological exponent realizes a feature bundle in a terminal node if the item matches all or a subset of the grammatical features specified in the syntactic node. Insertion does not take place if the vocabulary item contains features not present in the syntactic node. Where several vocabulary items meet the conditions for insertion, the item matching the greatest number of features specified in the syntactic node must be chosen.

In what follows, we adhere to the following division of labor between agreement mechanisms themselves and the principles that govern their realization. We assume that agreement intervention that is hierarchical in nature is syntactic. However, agreement restrictions that are demonstrably not hierarchical are postsyntactic. For example, the *g-/z-* constraint in Bizkaian Basque (Arregi and Nevins 2007) bans first plural and second person on the same auxiliary, regardless of which argument those features are on. Rather, the appropriate domain of the restriction is stated within the morphological word. Moreover, syntax-morphology linear mismatches such as

Ergative Displacement, to be discussed in section 5.3, are due to constraints on the linearization of a particular morpheme and hence, are by their very nature postsyntactic. Thus, a key component of the overall analysis we adopt is that the φ -sensitive restrictions operating throughout the auxiliary complex are parceled out into domains that may be hierarchical, morphological, or morphophonological, each operating with their own principles.

3. Basque clause structure

Finite sentences in Basque typically contain an analytical verbal complex, with a participle inflected for aspect,² and an auxiliary containing tense, agreement, clitics, and other inflectional affixes.³ The external argument of a transitive verb is ergative, and the object absolutive. On the other hand, unaccusative sentences always contain an absolutive argument, and no ergative argument.^{4,5}

- (4) *Su-k ni-Ø paño giau-Ø ekar-Ø d -o -su.*
 2S-E 1S-E than more-A bring-PRF PRE -PRS.3S -ERG.2S
 'You have brought more than me.' (353)
- (5) *Bakotx-a bere etze-an bixi d -a.*
 each-A.S 3S.G house-IN.S live PRE -PRS.3S
 'Each person lives in their house.' (360)

We assume the basic clause structure depicted in Figure 1, where HP is a projection for clitics that we introduce in Section 4. Ergative case is an inherent case assigned by transitive *v* to its specifier (Woolford 2006; Holguín 2007).⁶

We also assume that dative case is inherent, and assigned by Appl⁰ to its specifier.⁷ Absolutive case is the default case in Basque, and does not require case assignment of any sort. Basque is not a split ergative language along tense or aspectual lines.

The verbal forms in finite sentences are derived from the structure in Figure 1 as follows (Laka 1990). The participle is formed by movement of *V* to *v*, and of the *V-v* complex to *Asp*. This accounts for the appearance of an aspectual suffix on the main verb (e.g. *ekar-Ø* in (4) and *ego-n* in (6) below). The auxiliary is the result of several syntactic operations of agreement and cliticization (and postsyntactic operations discussed in 4.1). The root of the auxiliary, which we claim is in fact the realization of *T*, agrees

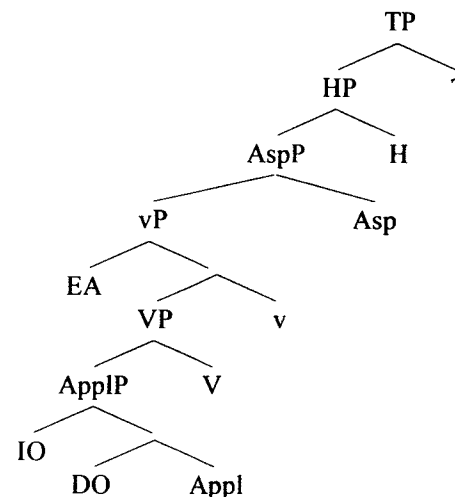

Figure 1. Basic syntax of Basque sentences

with the absolutive argument. This is in fact a controversial claim, and much of the present paper is dedicated to establishing it (see especially Section 6). In addition, there are morphemes in the auxiliary cross-referencing absolutive, ergative and dative arguments in the clause. Although these are commonly referred to as agreement morphemes (see, among others, Ortiz de Urbina 1989; Laka 1993a; Fernández and Albizu 2000; Rezac 2003), we claim that they are in fact pronominal clitics, as explained in detail in Sections 4–5.⁸ (4) contains an example of an ergative clitic; absolutive and dative clitics are illustrated in the following:⁹

- (6) *Lau aste-an ego-n n -as geixorik.*
 four week-IN be-PRF ABS.1S -PRS.1S sick
 'I've been sick for four weeks.' (367)
- (7) *Bat-an bat-eri emo-ngo d -o -tze -t.*
 one-G one-D give-FUT PRE -PRS.DEF -DAT.3S -ERG.1S
 'I'll give it to someone or other.' (361)
- (8) *Ondo etor-Ø d -a -tzu.*
 well come-PRF PRE -PRS.DEF -DAT.2S
 'You've deserved it.' (413)

The present analysis does not take into account two suffixes, *-s* and *-n*, that typically appear at the end of the auxiliary. These suffixes are traditionally described as realizing plural absolutive and past tense features, respectively. However, their distribution is much more complex than suggested by these claims.¹⁰

It should be clear from what we have said above that in Basque the mechanisms of case assignment and absolutive agreement are independent. Ergative and dative cases are inherent, and absolutive reflects the absence of any case assignment (indeed, it is available in nonfinite and nontensed environments such as fragment answers and left-dislocated arguments). Agreement occurs between T and the absolutive argument when it can, though as we discuss in Section 6.3, this Agree relation may be blocked and fail to be established, with detrimental effects on verbal agreement but with no change in the case of the absolutive argument.

A crucial claim made in this paper is that the root of the auxiliary is in fact the realization of a T head specified for tense and agreement. Previous work has often analyzed it as the realization of a lower functional head. For instance, Fernández and Albizu (2000) and Rezac (2003) claim that it is the realization of *v*. The main reason why we have not adopted this view is that it cannot account for some basic facts about the syntax-morphology mapping in Basque verbs. As discussed above, the participle (main verb) and the auxiliary form separate words in the syntax. Although they often appear adjacent, they clearly surface in separate parts of the structure in some contexts, such as matrix negative sentences (Laka 1990):

- (9) *Es s -eu -n iño-k urte-tan iño-ra.*
 not PRE PST.3S -N anybody-E leave-IMP anywhere-AL
 'Nobody went anywhere.' (359)

Under the assumption that the root of the tensed auxiliary is *v*, this head would have to undergo head movement to T (we omit here H and its projection):

- (10) [TP [AspP [VP [VP ... V] *t_v*] Asp] *v*-T]
-

However, this movement would skip the intervening Asp head, since the latter is part of the participle, not the auxiliary. This is a violation of the Head Movement Constraint (Travis 1984). Under the analysis defended here, this issue does not arise; movement of *v* to T does not occur, and the auxiliary root is the realization of T.

4. Clitic placement and the Person Case Constraint

All finite auxiliaries conform to the following template:

- (11) ABS clitic – tense/absolutive agreement – DAT clitic – ERG clitic¹¹

In our analysis, this template has no theoretical status, but is the result of the interaction of various syntactic and postsyntactic operations discussed throughout this paper. The basic syntax that underlies the positioning of morphemes in the auxiliary is shown in Figure 1. In this structure, the abstract head H (for *host*) is never realized overtly; its function is to attract certain clitics.

4.1. The syntax of pronominal clitics

Basque pronominal clitics can have ergative, dative, or absolutive case. These clitics are generated in argument position, and must be licensed by moving to certain functional heads that are only available in finite clauses. Specifically, dative and absolutive clitics must move to H, and ergative clitics must move to T.

Consider, for instance, the following transitive sentence:

- (12) *su-k gure ba-n -o -su*
 2S-E want if -ABS.1S -PRS.1S -ERG.2S
 'if you want me' (419)

In this sentence, the auxiliary contains the first singular absolutive proclitic *n-* and the second singular ergative enclitic *-su*. These also illustrate the obligatoriness of cliticization in Basque finite clauses. Being a pro-drop language for ergative, absolutive and dative arguments, Basque allows both arguments in this example to be null. However, the clitics must be present on the auxiliary, irrespective of the presence or absence of an overt argument.

We account for cliticization in Basque by adopting a form of the so-called *big DP* analysis, following Torrego (1992) and Uriagereka (1995). The clitic heads a DP whose complement is the DP argument (which can be null):

- (13) [_{DP} DP D_{Cl}]

D_{Cl} in this structure is the clitic, which must move to H (for absolutive/dative clitics) or T (for ergative clitics). With the exception of third person absolutive (see sections 4.2 and 5), all arguments in Basque are generated as big DPs. This structure accounts for obligatory clitic doubling in this language.¹²

Returning to the clause structure of transitive verbs Basque, the auxiliary in (12) is derived by moving the absolutive clitic to H and the ergative to T:¹³

- (14) [TP [HP [vP [DP DP t_{ERG}] [DP DP t_{ABS}]...]_{VP} H-ABS]_{HP} T-ERG]_{TP}
-

We assume that cliticization is a particular kind of head movement with certain properties. As illustrated in (14), it typically skips intervening heads (Kayne 1991). Furthermore, each clitic can adjoin only to a particular host: absolutive and dative clitics can only adjoin to H, and ergative clitics can only adjoin to T. An important consequence of this is that there are no intervention effects in clitic movement: the absolutive clitic in (14) skips the c-commanding ergative clitic on its way to H (since the specifier of vP is not a potential landing site), and the ergative clitic skips the absolutive clitic in H on its way to T (since H is not a potential landing site for ergative clitics).

The resulting structure is the input to Morphological Structure, which modifies it by merging the complex T and H heads, resulting in a single morphological word (Marantz 1988; Embick and Noyer 2001):

- (15) [H H ABS] [T T ERG] → [T [H H ABS] [T T ERG]]

Another important fact about the morphology of finite auxiliaries in Basque is that the head H is systematically ignored by postsyntactic rules. We implement this by positing a postsyntactic Fusion operation that conflates the terminal node H with its sister. When applied to the structure in (15), this results in the Fusion of terminal H with the absolutive clitic into a single node:

- (16) [T [H H ABS] [T T ERG]] → [T ABS [T T ERG]]

As we will see throughout this paper, the sister of H is not always an absolutive clitic. In some cases, it is a dative clitic, and in others, T (due to the lack of dative/absolutive clitics in the sentence). As a notational convention, we label the node resulting from Fusion with the label of the node that is fused with H. This reflects the fact that vocabulary insertion into the fused

node is not affected in any way by features that may be in H. The derivation of an intransitive sentence is similar, the main difference being that there is no ergative clitic adjoined to T. The analysis thus correctly derives the fact represented in (11) that absolutive clitics precede, and ergative clitics follow, the T head. We turn to the syntax of dative clitics, and some of its consequences for the morphology of finite auxiliaries.

4.2. Dative clitics and the PCC

The PCC is a condition on the combination of clitics and agreement morphemes that holds in many languages (see Perlmutter (1971), Bonet (1991), and much subsequent work). In Basque, it is instantiated by banning first and second person absolutive clitics in the presence of a dative clitic (Azkue 1923; Laka 1993a; Albizu 1997; Ormazabal and Romero 2007; Rezac 2006). This can be seen in the contrast between (7) (repeated here as (17)) and (18).

- (17) *Bat-an bat-eri emo-ngo d -o -tze -t.*
 one-G one-D give-FUT PRE -PRS.DEF -DAT.3S -ERG.1S
 'I'll give it to someone or other.' (361)

- (18) **Eur-ek su-ri ni-Ø sal-du n -o -tzu -e.*
 3S-E 2S-D 1S-A sell-PRF ABS.1S -PRS.DEF -DAT.2S -ERG.3P
 'They have sold me to you.'

Both auxiliaries contain a dative clitic. However, (17), with a (null) third person absolutive argument is grammatical, while (18), with a first person absolutive argument, is not.¹⁴

This follows in our analysis from the basic structure proposed in Figure 1 (page 5) combined with the following hypotheses:

- (19) Basque has no third person absolutive clitics.

- (20) H in Basque can only host one clitic.

Wiltschko (2008) makes a claim similar to (19) for Salish, in which some third person arguments would be expected to compete for positions but are lexically zero. In Basque, both absolutive and dative clitics must move to H, but the latter can only host one clitic. Thus, a sentence with both an absolutive and a dative clitic will crash (18). Given (19), this situation does

not arise if the absolutive argument is third person, since the absolutive argument remains in vP. The addition of a dative clitic does not result in ungrammaticality (17): the dative clitic moves to H. In essence, our claim is that (17) is grammatical because it has the same clitic syntax as a transitive sentence lacking an absolutive argument. The latter type of sentence can be illustrated with a verb like *jo* 'hit', which has the exceptional case assignment pattern ergative-dative:¹⁵

- (21) *bonete-agas jo-te Ø -o -sku -n a-Ø*
 hat-C.S hit-IMP PRE -PST.DEF -DAT.1P -REL that-A
 'that person who used to hit us with a hat' (285)

It is important to emphasize that the PCC, i.e. the fact that a dative clitic is only allowed when an absolutive clitic is third person, has nothing to do with the morphosyntactic features of third person. In fact, ergative and dative third person arguments do require clitic doubling. The PCC results from the fact that internal argument clitics compete for occupying the clitic position in H. There is only one position, and when there are two clitics, H simply cannot host both of them, so there is no well-formed syntactic derivation in this configuration. The only circumstance in which a dative clitic can surface, then, is when there is no absolutive clitic – either because the verb is exceptional in not selecting an absolutive argument, or in a sentence where there is no absolutive clitic because third person absolutive arguments simply have no clitic forms.

5. Clitic realization in the morphophonology

In the previous section, we have argued, contrary to some existing literature, that the apparent set of agreement prefixes and suffixes on the auxiliary root in Basque are in fact not the reflex of agreement at all, but instead clitics that double an argument. No such proposal would be complete without actually providing an account of the mapping from the abstract syntactic features of the clitic D^0 elements to their phonological form. In this section we provide a complete account of the realization of argumental clitics for ergative, dative, and absolutive.

Table 1. Basque clitics

	Absolutive	Ergative	Dative
First singular	n-	-t/-a	-t/-st
First plural	g-	-u	-ku/-sku
Second singular	s-	-su	-tzu
Second plural	s...-e	-su-e	-tzu-e
Third singular	—	-Ø/-o	-ko/-tze
Third plural	—	-Ø-e/-o-e	-ko-e/-tze-e

5.1. Clitics and morpheme order in the auxiliary

In the previous section we showed how certain syntactic and postsyntactic operations derive the basic template of finite auxiliaries:

- (22) ABS clitic – tense/absolutive agreement – DAT clitic – ERG clitic

The absolutive clitic precedes T as a result of cliticization to H. Cliticization of the ergative clitic results in right-adjunction to T, which accounts for its enclitic position (see (14)–(16)). Recall, furthermore, that dative clitics also move to H. After Merger and Fusion in the morphological component, the structure of a finite auxiliary with both a dative and an ergative clitic is the following:

- (23) [_T [_H H DAT] [_T T ERG]] → [_T DAT [_T T ERG]]

In this structure, the dative clitic precedes T. However, as shown in the template in (22), dative clitics are enclitic to T. We propose that this is due to a Metathesis rule that applies prior to Vocabulary Insertion. As a result of this Metathesis, the dative clitic and T are inverted, accounting for the attested order of morphemes within the auxiliary (for different cases of metathetic-type rules and accounts in the framework of Distributed Morphology, see Marantz (1988); Embick and Noyer (2001); Noyer (2001); Harris and Halle (2005) and section 5.3 below). All theories that identify the root as T and subscribe to some version of the mirror principle will have to account for why the dative clitic is syntactically lower than T but linearly to the right. That the dative is lower than T has been shown by the fact that it competes for H, yielding a ban on participant absolutive clitics, and by the intervention effects for T-absolutive agreement, which we discuss in 6.3.

5.2. The realization of clitics

Basque has a system of proclitics and enclitics for the various person-number features of the argument they correspond to. The forms of these clitics appear in Table 1. The vocabulary entries that realize in these clitics are the following:¹⁶

(24) Vocabulary entries for second person clitics

- | | | |
|----|--|-----|
| a. | /tzu/ ↔ [+Periph, +Part, -Auth] / T ____ | Dat |
| b. | /su/ ↔ [+Part, -Auth] / T ____ | Erg |
| c. | /s/ ↔ [+Part, -Auth] / ____ T | Abs |

(25) Vocabulary entries for first plural clitics

- | | | |
|----|---|-----|
| a. | /sku/ ↔ [+Periph, +Part, +Auth, -Sing] / [_T +Have] ____ | Dat |
| b. | /ku/ ↔ [+Periph, +Part, +Auth, -Sing] / T ____ | Dat |
| c. | /u/ ↔ [+Part, +Auth, -Sing] / T ____ | Erg |
| d. | /g/ ↔ [+Part, +Auth, -Sing] / ____ T | Abs |

(26) Vocabulary entries for first singular clitics

- | | | |
|----|--|---------|
| a. | /st/ ↔ [+Periph, +Part, +Auth, +Sing] / [_T +Have] ____ | Dat |
| b. | /a/ ↔ [+Part, +Auth, +Sing] / tze ____ s | Erg |
| c. | /t/ ↔ [+Part, +Auth, +Sing] / T ____ | Erg/Dat |
| d. | /n/ ↔ [+Part, +Auth, +Sing] / ____ T | Abs |

(27) Vocabulary entries for third person clitics

- | | | |
|----|--|-----|
| a. | /tze/ ↔ [+Periph, -Part, -Auth] / [_T +Have] ____ | Dat |
| b. | /ko/ ↔ [+Periph, -Part, -Auth] / T ____ | Dat |
| c. | /o/ ↔ [-Part, -Auth] / tze ____ | Erg |
| d. | ∅ ↔ [-Part, -Auth] / T ____ | Erg |

As discussed in the previous Section, the syntactic and postsyntactic rules, which apply prior to Vocabulary Insertion, determine that absolutive clitics precede T, and dative and ergative clitics follow T. Since clitics can be identified as proclitic or enclitic in this way after linearization, it is not necessary to specify case features in the vocabulary entries (with the exception of dative clitics, discussed below). The lack of case specification, especially in the proclitics, will provide a natural account for the phenomenon of Ergative Displacement below.

Consider, for instance, the second person clitics (24). Proclitic *s-* (24c) is inserted in a terminal that precedes T, that is, it realizes an absolutive morpheme. On the other hand, *-tzu* (24a) and *-su* (24b) are specified as following T, so that they spell out dative and ergative clitics, respectively. What distinguishes the latter two is the case feature [+Peripheral] on *-tzu*, which makes it dative. The vocabulary entries for first and third person in (25)–(27) are organized in a similar way.¹⁷

Another important feature of the clitic paradigm in Table 1 is the existence of two separate forms for all first and third person dative clitics. As reflected in the relevant vocabulary entries in (25)–(27), this allomorphy is dependent on the presence of the feature [+Have] in T. As shown in section 6.2 below, this feature is dependent on the presence of an ergative clitic in the auxiliary, and is crucial in accounting for several allomorphy phenomena in Basque finite verbs. In the particular case of dative clitics, it explains why *-sku* (first plural), *-st* (first singular) and *-tze* (third) are used in the context of an ergative clitic, while *-ku*, *-t* and *-ko* are used in the absence of an ergative clitic.¹⁸

All second and third plural dative and ergative clitics also contain the exponent *-e*. For instance, the second plural dative clitic is *-tzu-e* (as opposed to singular *-tzu*), and the third plural ergative clitic is *-∅-el-o-e* (as opposed to singular *-∅/-o*). We account for this fact by positing the following vocabulary entry:

(28) Vocabulary entry for plural clitic

- /-e/ ↔ [-Singular]

Basque is not unique in having a clitic dedicated to realizing number features; Noyer (2001) provides an extensive analysis of the Nunggubuyu non-singular clitic *wa*. In Basque, the discontinuous appearance of the clitic *-e* along with other clitics is the result of *Fission*. We propose that vocabulary insertion into clitics in Basque is subject to clitic Fission (Noyer 1992; Halle 1997). After insertion of the entry whose feature specification matches the most features in the morpheme (in accordance with the Subset Principle), Fission splits off the remaining (i.e. unrealized) features into a separate terminal of exponence. Vocabulary Insertion then proceeds onto this morpheme as usual. In particular, Fission accounts for the fact that all second and third plural clitics contain the additional enclitic *-e*, as discussed above. For instance, in the second plural ergative enclitic *-su-e*, *-su* matches the features [+Participant, -Author], and *-e* matches [-Singular]:

(29) *Clitic Fission in second plural ergative*

$$[+\text{Participant}, -\text{Author}, -\text{Singular}] \xrightarrow{(24b)} su [-\text{Singular}] \xrightarrow{(28)} su-e$$

Note that the plural enclitic *-e* never appears with first plural clitics. This is due to the fact that the more specific exponents in (25) already match [-Singular]:

(30) *No clitic Fission in first plural ergative*

$$[+\text{Participant}, +\text{Author}, -\text{Singular}] \xrightarrow{(25c)} u$$

One aspect of the entry in (28) is that it is not contextually restricted to clitics that precede or follow T, which entails that it can also be used to realize the [-Singular] feature of absolutive clitics. This is indeed the case, although perhaps not as transparently. Consider, for instance, the second plural absolutive auxiliary form *s-ara-e* (cf. singular *s-ara*). As with the second plural ergative clitic, the absolutive clitic in this auxiliary is realized with two exponents: *s-* (24c) matches the features [+Participant, -Author], and *-e* matches [-Singular]. Note, however, that *-e* appears after T, even though all other exponents for absolutive clitics precede T, as predicted by the structure in (15). This is due to the fact that the exponent in (28) is specified as an enclitic.

We now turn to the realization of third person absolutive. As shown in 4.2 above, our hypothesis that Basque has no third person absolutive clitics (19) explains the apparent PCC effects in this language. In terms of Vocabulary Insertion, this hypothesis is the basis for the lack of exponents for third person absolutive in (27). The entries in (27) can only be inserted in a clitic that follows T, and can thus never spell out an absolutive clitic, which is always linearly placed to the left of T. What we find preceding the root when there is no available proclitic is a special epenthetic prefix, which can be *d-*, *s-* or \emptyset . This phenomenon is intimately tied to the phenomenon of Ergative Displacement discussed in 5.3 below, in that both seem to satisfy a requirement that T be noninitial within the finite auxiliary.

The proposal is thus that third person absolutives do not require a clitic and thus no clitic is generated. The main clue that this is on the right track is the fact that the presence of a third plural absolutive argument does not trigger the insertion of the plural enclitic *-e*. If a third person absolutive clitic were present in the auxiliary, we would also expect clitic Fission and the insertion of plural enclitic *-e* in the context of a third person absolutive

argument. As can be seen in the paradigm in Table 1 (p. 59), this is not the case. The proposal that there are no third person proclitics is additionally supported by the analysis it affords for PCC effects in Basque (4.2 above), and from the phenomenon of Ergative Displacement, to which we now turn.

5.3. Ergative Displacement

Crucial to the claim that there are no third person proclitics in Basque is a discussion of the resulting morphophonological effect on the auxiliary root. There is a requirement in Basque that T (i.e. the root of the auxiliary) not be word-initial, essentially a second position constraint. When there is a first or second person absolutive argument, this requirement is satisfied by an absolutive proclitic. However, since there is no such clitic when absolutive is third person, Basque resorts to two different strategies to satisfy the requirement: (i) an epenthetic prefix (*d-*, *s-* or \emptyset -, as discussed below) is inserted, or (ii) if there is an ergative clitic present, the features of the ergative clitic are borrowed in the past tense. We examine these two operations briefly here, and refer the reader to a formal account developed in Arregi and Nevins (2008).

In examples such as (31), the clitic *s-* in initial position corresponds to the features of the ergative argument, but it is in the place that the absolutive clitics normally show up, and it takes the same form that absolutive clitics normally have (thus compare (31), where the second singular ergative is proclitic *s-*, with (4), where it is enclitic *-su*). Following Laka (1993a), we call this phenomenon *Ergative Displacement* (ED).

- (31) *pro.2S.E i-ten s -endu -n au-∅.*
pro.2S.E do-PRF ERG.2S -PST.3S -N this-A
 'You used to do this.' (387)

The observation that third person absolutive is somehow defective in Basque and the relation of this defectivity to ED is due to Azkue (1923). This insight is crucial in understanding several aspects of Basque verbal morphology, and has been adopted in one way or another by virtually all previous formal accounts of verbal inflection in Basque since Bossong (1984) and Laka (1993a) (see, among others, Gómez and Sainz 1995; Albizu and Eguren 2000; Fernández and Albizu 2000; Rezac 2003; Béjar and Rezac 2004; and Rezac 2006).¹⁹

When there is no proclitic (because the absolutive is third person), we propose that, prior to Vocabulary Insertion, an operation of Metathesis transfers the ergative clitic to word-initial position in the past tense, in order to satisfy the second position condition on T.²⁰

- (32) *Ergative Metathesis*
 # T ERG → # ERG T
 Condition: T is [+Past]

We view the implementation of this movement not as the result of actual syntactic movement (i.e. no dominance relations actually change in a tree), but rather as the operation of a postsyntactic Metathesis rule (Marantz 1988; Embick and Noyer 2001; Noyer 2001; Harris and Halle 2005).

The derivation of the ED example (31) proceeds as follows. In the syntax, T agrees with the third singular object, and the ergative clitic moves to T. After Merger and Fusion in the morphological component, the finite auxiliary has the structure in (33). Crucially, as no clitic is adjoined to the left of T, due to the fact that the absolutive argument is third person, this structure must undergo Metathesis:

- (33) [_T T_{PST.3S} ERG_{2S}] → [_T ERG_{2S} T_{PST.3S}] → [_T s- endu]

Following linearization and this Metathesis operation, these terminal nodes are assigned exponents through the process of Vocabulary Insertion. The relevant exponents are *-su* (24b) and *s-* (24c).²¹ The reader will notice that the vocabulary items *s-* and *-su* differ only in terms of their linear position, not their case features. In non-ED contexts, the absolutive proclitic precedes T, and the ergative clitic follows it, so *s-* is the realization of second person absolutive and *-su* realizes second person ergative in these contexts. However, the lack of case features in the vocabulary entries predicts that this correlation between the case of the clitic and its realization might be disturbed if some rule alters the linear order of clitics in a relevant way. This is precisely what happens when Metathesis (32) applies. Since the ergative clitic precedes T due to Metathesis, the entry for enclitic *-su* (24b) cannot be used, and the proclitic *s-* (24c) is inserted instead. The end result is that the ergative clitic's morphosyntactic features are realized in the same position and with the same form as an absolutive clitic in non-ED contexts.

As formulated, the Metathesis rule (32) predicts that ED applies to ergative clitics regardless of their feature specification. However, due to an observation made independently by Bossong (1984) and Ortiz de Urbina (1989),

it is a standard claim in the literature that ED does not apply when the ergative clitic is third person (see all references on ED cited above). These authors observed that in ED contexts, a third plural ergative argument is not referenced by a proclitic, but rather by an enclitic, which is unexpected if wholesale conversion of ergative to absolutive were taking place in ED. This is illustrated in the following Zamudio example, where enclitic plural *-e* crossreferences a (null) third plural ergative argument (see section 5.2):

- (34) *baye* [_{CP} *almuda-n igual ollosko-a forme-ta*
 but [_{CP} *pillow-IN.S perhaps chicken-A.S materialize-IMP*
*s -a -la] *esa-te* Ø *-eur -e -n.*
 PRE PST.3S -COMP] *say-IMP PRE -PST.3S -ERG.P -N*
 'but they say that perhaps a chicken used to materialize on the pillow'
 (403)*

Their conclusion is that the auxiliary in (34) does not contain a proclitic; rather, the ergative is realized as an enclitic as usual, and there is no ED.

However, under our analysis of clitics in section 5.2, this conclusion is not warranted. Consider the derivation of the auxiliary in (34) under the assumption that ED in fact does apply. The output of the syntax and Merger and Fusion of H and T is an auxiliary with an ergative clitic adjoined to a past tense T with third singular features (due to agreement with the absolutive argument). Metathesis applies to this structure yielding the following:

- (35) [_T T_{PST.3S} ERG_{3P}] → [_T ERG_{3P} T_{PST.3S}] → [_T Ø- eu -e]²²

Since none of the vocabulary entries for proclitics (24)–(26) match the third person specification of the ergative clitic node, the auxiliary is simply left with no exponent for the proclitic position. On the other hand, the vocabulary entry for enclitic *-e* (28) does match [–Singular] in the ergative clitic's set of morphosyntactic features. The net result is that the ergative clitic is realized with only enclitic *-e*. The proclisis of the ergative occurs, but yields no phonological exponent as a prefix. However, ordinary plural enclisis still occurs.

Finally, Ergative Metathesis cannot always be used to satisfy the requirement that T not be word-initial within the finite auxiliary. As noted above, this requirement can also be satisfied by inserting a prefix, which can be *d-*, *s-* or Ø-. These are inserted whenever Ergative Metathesis does not apply (i.e. T is present tense or there is no ergative clitic), or when Metathesis inverts a third person ergative clitic for which there is no enclitic form, as

discussed above. We view this epenthetic insertion of a prefix as a last resort postsyntactic rule that applies prior to Vocabulary Insertion in order to satisfy the noninitiality requirement on T. Specifically, the rule inserts a terminal node to the left of T, which is realized at Vocabulary Insertion by one of the prefixes mentioned above. The distribution of these prefixes is somewhat complex, and can be summarized as follows (see Arregi and Nevins (2008) for details): *d-* is inserted in the present, *s-* appears in past auxiliaries when the ergative clitic is absent or agreement in T is third person plural, and \emptyset - is used elsewhere in the past tense.

Note that the noninitiality requirement on T is morphological in nature, not phonological. As a consequence, the two rules discussed above (Metathesis and insertion of a prefix) manipulate terminal nodes in the structure of the auxiliary, and apply prior to Vocabulary Insertion. This is seen most clearly in the fact that the requirement can be satisfied by the prefix \emptyset .

To conclude, contexts with a third person absolutive argument lead to a variety of morphological operations to satisfy the noninitiality requirement of the auxiliary root T, which can be well-characterized as proxies for the failure of these arguments to generate an associated clitic.

6. Agreement by T with the absolutive

Having argued that a majority of the pieces of the Basque auxiliary complex that have been traditionally analyzed as agreement markers are in fact clitics, we turn to what we argue is a true instantiation of bona fide agreement by T, as modeled with the Agree operation. This Agree operation establishes a relation of feature valuation between the φ -features on T and those of the absolutive argument. In this Section, we discuss the basic Agree operation between T and the absolutive (6.1), the morphophonological realization of the φ -features that T acquires (6.2), and the voiding of an Agree relation by a dative intervener (6.3).

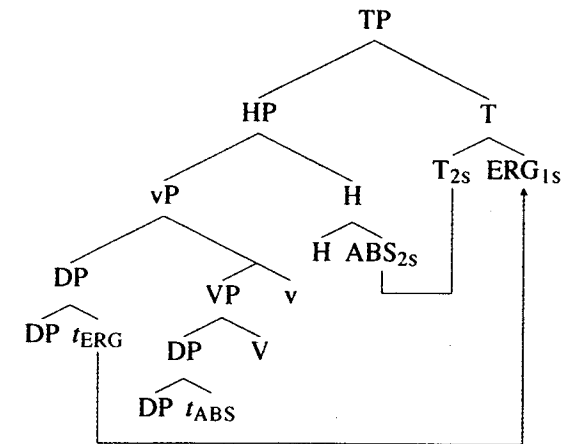

Figure 2. Movement of ergative clitic and agreement of T with absolutive clitic

6.1. Agree between T and the absolutive

As mentioned above, we identify the root of the finite auxiliary as the realization of the head T. In order to understand how agreement affects the realization of the root, we first discuss sentences with a first or second person absolutive argument, and then sentences with a third person absolutive argument. In both cases, Agree occurs, though the syntactic position of the Goal differs slightly.

A sample derivation with a second person singular absolutive argument and a first person singular ergative argument is shown in Figure 2. After the absolutive clitic moves to H, T is merged and triggers two operations: (i) it attracts the ergative clitic, and (ii) it agrees with the absolutive clitic in H.²³ In an intransitive sentence, the derivation is the same, except for the fact that there is no ergative argument, so there is no clitic movement to T.

Due to the fact that third person absolutive arguments do not generate a clitic that moves to H (see Sections 4.2, 5), the derivation of agreement with T and the absolutive is slightly different. T in this case establishes an Agree relation with the absolutive argument itself, in situ in VP.²⁴ This is shown in Figure 3.

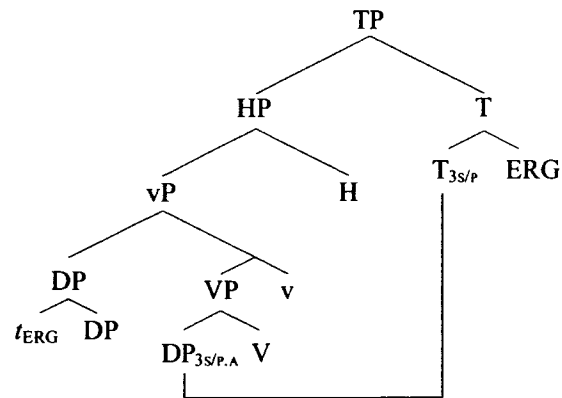

Figure 3. Agreement of T with third person absolutive argument

Importantly, in these cases, while the ergative clitic has moved to T, the ergative argument still intervenes between T and the VP-internal absolutive argument. We thus assume that clitic-doubling of an argument *A* renders the original argument *A* invisible for Agree operations (see Anagnostopoulou (2003: 206–215) and references cited there). This locality must be evaluated representationally, for instance at the phase-level derivational step reached with the merge of matrix C, by which point the agreement relation between T and the absolutive in VP crosses the trace of the ergative clitic in the specifier of vP.

The derivation of an Agree relation between T and the absolutive argument thus depends indirectly on whether the absolutive has triggered clitic doubling or not. If it does, then T agrees with the absolutive clitic in H. If it does not, then T agrees with the absolutive argument itself, within VP. The configurations we have just described are simple cases of Agree with the closest D element in the asymmetric c-command domain of a probing head. Moreover, this Agree operation is one in which the Goal is not inherently case-marked, and hence visible for agreement. Although in this type of configuration, there is no intervening D element, we will see below that this is not always the case, namely when a dative argument intervenes, which results in lack of agreement.

As we will see in the next subsection, the realization of successful Agree valuation of T's φ -features is subject to a good deal of allomorphy, often tense-dependent—which is what one might expect of agreement (as opposed to clitics).

6.2. The realization of agreement on T

The person/number features acquired by T via agreement with the absolutive argument are crucial in understanding its realization by vocabulary entries. In addition, T shows a variety of allomorphs depending on the presence or absence of an ergative clitic. This apparent *have/be* alternation, indirectly conditioned by the argument structure of the verb, will figure in our discussion as well. As can be seen in Tables 2–4 (pages 71–72), the form of T is highly dependent on the features of the absolutive argument, as well as the feature $[\pm\text{Past}]$.²⁵

Furthermore, these Tables also show that the realization of T is also dependent on the presence or absence of an ergative clitic (and, to a limited extent, on its feature content). We implement this latter fact with the following rule, which applies prior to Vocabulary Insertion:

- (36) Insert the feature [+Have] in T in the context of an ergative clitic.
 Insert [-Have] otherwise.

For ease of exposition, we refer to T specified as [+Have] as *transitive T*, and to T specified as [-Have] as *intransitive T*.

The fact that the form of the root depends on the presence/absence of an ergative clitic might lead to the hypothesis this is the same phenomenon as the *have/be* alternation in many Romance and Germanic languages. However, Arregi (2004) presents thorough argumentation that the alternation in Basque is based on the presence/absence of an ergative clitic on the auxiliary, and not on the ergative DP argument (i.e. transitive/intransitive syntax). That this is the case can be best detected when ergative cliticization and ergative arguments part ways.

One demonstration that [+Have] allomorphy depends on the presence of an ergative clitic comes from allocutive auxiliary forms in Zamudio. In many dialects of Basque, a distinction is made between second singular formal and colloquial forms. Due to the marginal status of this opposition in Zamudio, we have only reported formal forms (glossing them as second singular). However, Gaminde (2000) has collected some colloquial forms, including allocutive ones. Allocutive finite forms in Basque are unique in that they contain a second person clitic that agrees with the addressee when the latter is someone who would be addressed using colloquial forms (Oyharçabal 1993). Importantly, this clitic does not crossreference any DP in the clause, hence the name *allocutive*. Of interest for the present discussion is the particular form that allocutive clitics have. In an intransitive auxiliary

with only an absolutive clitic, the allocutive clitic is realized as an enclitic. (38) is the allocutive counterpart of (37).²⁶

(37) *Lau aste-an ego-n n -as geixorik.*
four week-IN be-PRF ABS.1S -PRS.1S sick
'I've been sick for four weeks.' (367)

(38) *Lau aste-an ego-n n -o -k geixorik.*
four week-IN be-PRF ABS.1S -PRS.1S -ALL.2S.COLLM.M sick
'I've been sick for four weeks.'

Both sentences in (38) have the same syntax and meaning: they are syntactically intransitive, in the sense that they contain a single absolutive argument. The only difference is that (38) is used whenever addressing a male friend, and (37) is more formal. The allocutive auxiliary in (38) contains the additional allocutive enclitic *-k*, which does not crossreference any DP in the sentence.²⁷ Furthermore, this allocutive clitic has the same form and occupies the same position as an ergative clitic.

Crucially for the discussion of the distribution of [\pm Have] is the fact that T (the root) takes a different form in both examples in (38). While in both, T agrees with the first singular absolutive argument, T in the nonallocutive auxiliary (37) is intransitive *as*, as expected, but T in the allocutive auxiliary (38) is transitive *o* (see below for the relevant vocabulary entries). Even though the sentence lacks transitive syntax and an ergative argument, the syntactically unmotivated presence of a clitic with the form and position of an ergative clitic triggers the insertion of transitive T. Thus, (38) shows that ergative cliticization, and not an ergative argument, triggers the presence of transitive T.

Thus, the transitivity alternation in the realization of T in Basque is determined by the presence of an ergative enclitic in the auxiliary that does not necessarily signal the presence of an ergative argument, and is thus a postsyntactic determination of allomorphy. We turn to an exhaustive listing of the interaction between tense, [\pm Have], and agreement with the absolutive in determining the allomorphs of T. The vocabulary entries for intransitive T are the following (see Table 2):

Table 2. Intransitive T

Absolutive	Present	Past
First singular	as	entz
First plural	ara	intz
Second singular	ara	intz
Second plural	ara	intz
Third singular	a	a
Third plural	ire	ire

Table 3. Present transitive T

Ergative	Absolutive					
	1 sing.	1 plural	2 sing.	2 plural	3 sing.	3 plural
1 sing.	X	X	aitu	aitu	o	o
1 plural	X	X	<u>ara</u>	<u>ara</u>	o	o
2 sing.	o	o	X	X	o	o
2 plural	o	o	X	X	o	o
3 sing.	eu	aitu	aitu	aitu	eu	eitu
3 plural	eu	aitu	aitu	aitu	eu	eitu

(39) *Vocabulary entries for first singular intransitive T*

- a. /entz/ \leftrightarrow [-Have, +Past, +Part, +Author, +Singular] Past
b. /as/ \leftrightarrow [-Have, -Past, +Part, +Author, +Singular] Present

(40) *Vocabulary entries for first plural/second person intransitive T*

- a. /intz/ \leftrightarrow [-Have, +Past, +Participant] Past
b. /ara/ \leftrightarrow [-Have, -Past, +Participant] Present

(41) *Vocabulary entry for third plural intransitive T*

- /ire/ \leftrightarrow [-Have, -Participant, -Author, -Singular]

(42) *Default vocabulary entry for intransitive T*

- /a/ \leftrightarrow [-Have]

These vocabulary entries account for the forms of T in Table 2 in a straightforward way. The following are the entries relevant to transitive T (see Tables 3–4):²⁸

Table 4. Past transitive T

Ergative	Absolutive					
	1 sing.	1 plural	2 sing.	2 plural	3 sing.	3 plural
1 sing.	X	X	endu	endu	endu	endu
1 plural	X	X	endu	endu	endu	endu
2 sing.	endu	endu	X	X	endu	endu
2 plural	endu	endu	X	X	endu	endu
3 sing.	endu	endu	endu	endu	eu	eitū
3 plural	endu	endu	endu	endu	eu	eitū

(43) *Vocabulary entry for participant transitive T in the present*
/aitu/ ↔ [+Have, -Past, +Participant]

(44) *Vocabulary entries for third person transitive T*
a. /eitū/ ↔ [+Have, -Participant, -Author, -Singular] 3.PL
b. /eu/ ↔ [+Have, -Author] 3.SG

(45) *Default vocabulary entries for transitive T²⁹*
a. /endu/ ↔ [+Have, +Past] / [+Participant] ____
b. /o/ ↔ [+Have]

The entries in (44) assign the correct exponents to T in the third person (*eu*, *eitū*), except in the environment of a participant ergative clitic. In the latter context, T is realized as the default *o*/*endu* (in the present and the past, respectively; see (45)), due to the following Impoverishment rule, which deletes person features in T:

(46) *Third Impoverishment*
[+Have, -Part, -Author] → [+Have, -Part] / ____ [-Peripheral, +Part]

This rule applies after (36) and prior to Vocabulary Insertion. The following example illustrates this rule:

(47) *Beskari-e i-n d -o -t.*
lunch-A.S make-PRF PRE -PRS.3S -ERG.1S
'I've made lunch.' (388)

In the syntax, the first singular ergative clitic moves to T, and the latter agrees with the third singular absolutive argument. The presence of this er-

gative clitic triggers the application of (36), so that T is specified for [+Have], as well as present tense and the φ -features of the absolutive:

(48) [+Have, -Past, -Participant, -Author, +Singular]

Since the presence of the first singular ergative clitic provides the context for the deletion rule (46), the auxiliary ends up with the following feature specification:

(49) [+Have, -Past, -Participant, +Singular]

As T in this case lacks the specification for [-Author], *eu* (44b) cannot be inserted, and it is realized with the default *o* (45b).

In the present, second person is realized as *aitū* (43). In the past, there are no particular entries applying to second person, so T is realized as the default *endu* (45a). The same is true for first person singular in the past. However, in the present tense, the auxiliary shows a syncretism between first singular and third singular agreement. This is arguably due to a markedness-based Impoverishment rule, like one found in German (Müller 2005). In Basque, first person singular is impoverished in the present ((50), which applies before (46)), so that its postsyntactic feature composition is identical to that of third singular.

(50) *First Singular Impoverishment*
[+Have, -Past, +Participant, +Author, +Singular] →
[+Have, -Past, -Participant, -Author, +Singular]

Due to this rule, first person singular is realized as *eu* or *o*, just like the third person singular. Finally, first person plural is realized as default *endu* in the past. In the present, the realization of first plural is affected by the following Impoverishment rule, which applies before (46):

(51) *First Plural Impoverishment*
[+Have, -Past, +Part, +Auth, -Sing] →
[+Have, -Past, -Part, -Auth, -Sing] / ____ [-Peripheral, +Part]

This rule impoverishes first person plural to third person in the present in the context of a participant ergative clitic. As a consequence, T is realized as *o* (45b) in this context (due to the further application of (46)). Otherwise, first person plural is realized as *aitū* (43) in the present tense.

6.3. Dative intervention and default agreement

In Section 6.1 we discussed the derivation of Agree between T and the absolutive for intransitive and transitive clauses. However, the combination of absolutive and dative arguments in a Basque sentence gives rise to a separate phenomenon within the finite auxiliary. One of the central claims that we have made in this paper is that the root of the auxiliary is T, which must agree with the absolutive argument. As discussed in Subsection 6.1, this agreement operation satisfies standard locality conditions: T agrees with an absolutive DP x in its c-command domain as long as there is no intervening DP y between T and x . Clauses with both absolutive and dative arguments illustrate one such case where an intervener blocks agreement by T and the absolutive argument.

Due to the clitic competition resulting in restricted absolutive-dative argument combinations, as discussed in 4.2, the only type of clauses with a dative argument that are eligible for Agree are those with a third person absolutive argument (which, as we have seen in 6.1, normally triggers agreement). In these sentences, the dative cliticizes to H, and the absolutive remains in VP (since there are no third person absolutive clitics). As shown in Figure 4, agreement with the absolutive DP is blocked by the dative clitic in H. Thus, the analysis predicts that T must take a default form whenever the auxiliary contains a dative clitic. This prediction is borne out. The distribution of the different forms of T in the context of dative clitics can be summarized as follows:³⁰

(52) *Forms of T in the context of a dative clitic*

- a. Intransitive T: *a* (42)
- b. Present transitive T: *o* (45b)
- c. Past transitive T: *o* (45b) or *eun* (53a)

Cases (52a)–(52b) are straightforward: if there were no intervention by dative clitics, we would expect T to agree with the absolutive argument; however, T has a default form in both cases. Case (52c) also confirms the prediction, but is somewhat more complicated, and merits some discussion. The realization of T in this case is summarized in Table 5. The relevant vocabulary entries are (53a), which is new, and (45a) and (45b), repeated here as (53b)–(53c).

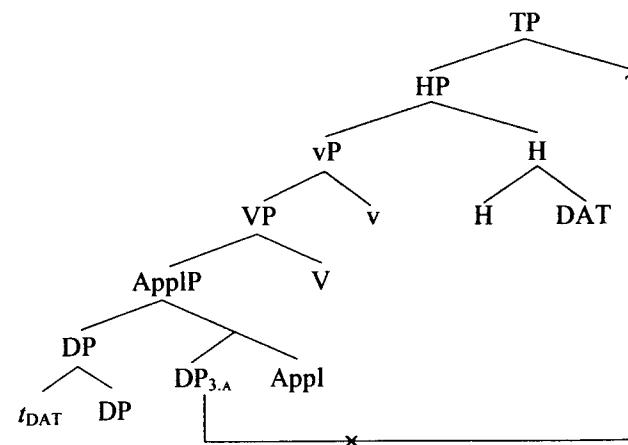

Figure 4. Dative intervention

Table 5. Past transitive T in the context of a dative clitic

Ergative	Dative					
	1 sing.	1 plural	2 sing.	2 plural	3 sing.	3 plural
1 sing.	X	X	eun	eun	eun	eun
1 plural	X	X	eun	eun	eun	eun
2 sing.	o	<u>endu</u>	X	X	eun	eun
2 plural	o	<u>endu</u>	X	X	eun	eun
3 sing.	o	o	o	o	o	o
3 plural	o	o	o	o	o	o

(53) *Default vocabulary entries*

- a. /eun/ ↔ [+Have, +Past] / [+Participant] ____ [+Peripheral]
- b. /endu/ ↔ [+Have, +Past] / [+Participant] ____
- c. /o/ ↔ [+Have]

All these entries are potential candidates to realize default past transitive T in case (52c), since none of them are specified for any agreement feature. Of relevance here is the fact that past transitive auxiliaries undergo Ergative Metathesis (section 5.3), which places ergative clitics before T in the absence of an absolutive proclitic. Due to the PCC (section 4.2), past transitive forms with a dative clitic are only possible if the absolutive argument is

third person. These forms additionally undergo Ergative Metathesis. A metathesized participant ergative clitic triggers the insertion of *eun* (53a) in T (see Table 5).³¹

In cases where the metathesized ergative clitic is third person (or when Metathesis fails to apply; see note 31), both *eun* (53a) and *endu* (53b) are blocked, since they can only be inserted in the context of a participant proclitic. The result is that, as shown in Table 5, *o* (53c) is inserted wherever *eun* is not. Finally, *endu* (53b) is limited to transitive auxiliaries with no dative clitic, as can be seen in Tables 4–5.

To conclude, the realization of T in the context of a dative argument and the absence of the otherwise expected number distinctions provides a strong argument for the claim that the root is in fact a head (T) that agrees with the absolutive argument. As expected, intervention by the dative argument blocks this agreement relation, and T takes a default form.

6.4. Clitic competition and agreement intervention

We have discussed two syntactic effects that dative clitics may have on the realization of absolutive arguments. The first concerned the fact that as datives and absolutives are in the same syntactic domain, their clitics compete for HP (Section 4.2). Thus, when there is a dative clitic, the absolutive clitic cannot be hosted. This yields the apparent Person Case Constraint on clitics in Basque. There is a wide range of repair strategies that various dialects of Basque use in order to circumvent the Person Case Constraint, but the ultimate fact is that a combination of both absolutive and dative clitics in Basque simply cannot surface. Thus, dative competition results in an absolute ban on absolutive clitics in the presence of datives.

When it comes to the higher head T whose attempt at Agree with a third person absolutive argument is blocked by the intervening dative, the result of this failure to agree is not absolute ungrammaticality, but rather simply a failure to record the agreement features of the absolutive argument on T (Subsection 6.3). Thus, as in Icelandic (see, among others, Holmberg and Hróarsdóttir 2004), blocking of T's agreement path yields default agreement (i.e. no syntactic agreement, and Vocabulary Insertion of the elsewhere item). Thus, for the purposes of dative intervention, the blocking of an Agree relation between T and the absolutive argument does not result in absolute ungrammaticality, but simply failure to copy the features of the absolutive and hence a default vocabulary item for T.

7. Summary

The Basque auxiliary shows a number of agreement and clitic restrictions. We have proposed that some of these are due to syntactic operations and some are due to postsyntactic operations.

The relevant syntactic operations that occur in Basque are cliticization of ergative, dative, and (nonthird) absolutive arguments, and an Agree operation between T and the absolutive argument. When cliticization yields two internal argument clitics, one source of agreement restrictions is the competition for occupying H. When the dative clitic intervenes between T and the absolutive argument, another source of agreement restrictions is the intervention condition on Agree. These two agreement restrictions find a number of crosslinguistic parallels and can be understood in terms of well-motivated limitations on the syntactic computation.

Thus, while third person absolutive arguments in Basque behave differently from both third person ergative and from other absolutive arguments (i.e., allowing dative-absolutive combinations, and inducing Ergative Displacement), we have not attributed this to anything specific about the morphosyntactic features of third person. It is simply due to the lack of a clitic realization of this argument, which has consequences only because of the nature of the clitic-hosting head, and because of the noninitiality requirement of the Basque auxiliary root.

A number of postsyntactic operations occur in the Basque auxiliary, which fall into two basic categories. One set of operations are Impoverishment rules, which are rules of postsyntactic feature-deletion that are largely motivated by considerations of morphological markedness. A second set of operations are Metathesis rules, which are responsible for the mismatch between the hierarchical and surface position of the dative clitic, and which play a crucial role in understanding the rule of Ergative Metathesis. Both sets of operations find numerous crosslinguistic parallels: Impoverishment rules yield syncretism in the realization of agreement in a wide range of languages, and Metathesis rules occur to satisfy second position requirements in a number of domains. Importantly, neither of these operations are responsible for agreement restrictions per se; they are operations that yield a number of syntax-morphology mismatches and which operate over the currency of φ -features, but they do not refer to hierarchical structure in the way that the syntactic operations above do. The resulting picture is one in which the seeming complexity of Basque auxiliary morphology results from the interaction of a number of independent principles operating in distinct subdomains of the grammar.

Notes

1. Example sentences from Gaminde (2000) are cited by giving the page number in parenthesis. In cases where that work does not have relevant examples, we have consulted de Yrizar (1992, 1: 585–625), which contains a detailed inventory of finite auxiliary paradigms in this dialect. All forms are given here in their underlying forms after Vocabulary Insertion (Sections 5.2 and 6); they are further modified by readjustment and phonological rules discussed in Arregi and Nevins (2006). The data are transcribed using the orthographic conventions in Gaminde (2000). The reader not familiar with Basque spelling rules should take into account the following: \tilde{n} is a palatal nasal [ɲ], $(t)x$ is a voiceless alveopalatal fricative/affricate [(t)ʃ], tz is a voiceless alveolar affricate [ts], and y is a palatal obstruent with different realizations.
2. The participle can also be inflected for future, as in (7).
3. A reduced number of verbs can also appear in simple tenses; see Gaminde (2000).
4. We use the following abbreviations: Abs/A (absolute), ABS (absolute clitic), AL allative, ALL (allocutive clitic), C (comitative), COLL (colloquial), Dat/D (dative), DAT (dative clitic), DEF (default agreement), Erg/E (ergative), ERG (ergative clitic), G (genitive), FUT (future), IMP (imperfective), IN (inessive), M (masculine), N (-*n* suffix), NF (nonfinite inflection), NOM (nominative), Pl/P (plural), PRE (epenthetic prefix), PRF (perfective), PRS (present), PST (past), REL (relativizing suffix), Sg/S (singular).
5. In the examples below, some auxiliaries contain the prefix *d*, glossed as PRE. On the status of this morpheme, see section 5.3.
6. Unergatives assign ergative to their argument, but Laka (1993b) shows that these are really transitives, as proposed by Hale and Keyser (1993).
7. We assume that the indirect object is the specifier of a low applicative head whose complement is the direct object. See Larson (1988), Marantz (1993), Pesetsky (1995), and Pylkkänen (2002) for relevant discussion.
8. The form of these morphemes resembles that of (nonclitic) pronouns. This justifies in part the adoption of the clitic analysis, and has been taken as evidence for the claim that these morphemes are historically derived from pronouns (Gómez and Sainz (1995) and references cited there).
9. These examples also show that DPs cross-referenced in the auxiliary can be pro-dropped.
10. There is a morphological distinction between colloquial and formal in the second singular. We have omitted inclusion of this aspect of Basque morphology, since our main source on Zamudio contains very few colloquial auxiliary forms, reflecting the loss of the formal/colloquial contrast in favor of formal forms. The present paper only discusses indicative auxiliary paradigms, since the nonindicative auxiliary forms and finite forms of main verbs are greatly leveled in Zamudio (Gaminde 2000).
11. There is a well-defined class of exceptions to this template. In certain environments, the absolutive clitic position is occupied by certain special prefixes or by an ergative clitic. The morphological operations responsible for these cases are discussed in 5.3.
12. Cliticization is impossible in nonfinite clauses. This is due to the fact that the latter do not have the relevant heads that host clitics (H and T). Thus, arguments are generated as big DPs only in finite clauses.
13. We omit the Asp projection from Figure 1 in all diagrams below for ease of exposition. The auxiliary in this example also contains absolutive agreement (see Section 6).
14. Gaminde (2000: 372) has some forms that apparently violate the PCC. Specifically, these are present tense intransitive forms with a dative clitic and a first singular absolutive clitic. However, the paradigm is greatly leveled, and is limited to the aforementioned forms (e.g. there are no past tense forms nor ones containing a first plural absolutive clitic). Secondly, as has been noted for many other Basque dialects, they are limited to intransitive low dative sentences, and are not allowed in sentences that have the structure in Figure 1, where both the dative and absolutive are internal arguments generated under vP, such as unaccusative psych verb sentences and ditransitive sentences (see Rezac (2006) for discussion). Since the syntax of dative and absolutive arguments is crucial in our explanation of PCC effects in Basque, and it is not clear to us what the syntax of these apparent PCC violating sentences should be, we leave this as a matter in need of further research. We thank Iñaki Gaminde for clarifying the data for us.
15. Note that the auxiliary in (21) undergoes ED (section 5.3), since it is in a past tense ditransitive sentence. This is not completely transparent, since the ergative clitic that undergoes ED is third person, and thus is not realized by any vocabulary entry.
16. In some forms, a first plural clitic is missing in the context of a second person clitic. This is due to the *g-/z-* constraint, discussed in Arregi and Nevins (2007).
17. As in the second person, the realization of dative and ergative clitics is different in the first and third persons, with one exception. In the first singular, enclitic *-t* is the default exponent for both dative and ergative clitics.
18. Other alternations present in Table 1 not discussed in the text are the following. First, the exponent of third person ergative can be $-\emptyset$ or *-o*. As shown in the entries in (27c)–(27d), *-o* is a very specific allomorph of third ergative inserted in the context of the third singular dative clitic exponent *tze*, and $-\emptyset$ is the default third ergative exponent. Second, *a* (26b) is a very specific allomorph of first singular ergative inserted when preceded by aforementioned *-tze* and followed by the so-called plural suffix *-s* (see discussion below (8)). Otherwise, the default realization of first singular ergative is *-t* (26c).
19. For other accounts of ED, see Ortiz de Urbina (1989), Heath (1976), and Hualde (2002).

20. In many dialects of Basque, there are particular exceptions to this Metathesis rule. In Zamudio, Metathesis does not apply in the context of a first singular dative clitic. We assume that this is due to dialect-particular conditions on the application of Metathesis.
21. Past tense T in the example contains third singular absolutive agreement, which is realized as *endu* (see section 6.2). This auxiliary also contains the suffix *-n*, not dealt with in this paper (see discussion below (8)).
22. T in this auxiliary is realized as *eu* (section 6.2), which is further modified to *eur* by readjustment rules (Arregi and Nevins 2006).
23. Following Anagnostopoulou (2003), we assume that the ergative clitic adjoined to T is in the minimal domain of T, and thus does not block the Agree relation between T and the absolutive clitic.
24. Thus, either vP is a weak phase in Basque, or it is a strong phase and consistent with the definition of the Phase Impenetrability Condition in Chomsky (2001) in which a strong phase remains accessible until the next phase head up, which is C, not T.
25. As in all dialects of Basque, reflexive auxiliary forms (first with first, second with second) are not possible in Zamudio Basque. This is reflected in Tables 3–4 and all other Tables in this paper by the symbol X in the relevant cells. On the underlined forms in Table 3, see note 28.
26. Unfortunately, Gaminde (2000) does not have any relevant sentence containing allocutive forms, which reflects the fact that these forms are not in much use any more. Gaminde lists the allocutive form *n-o-k* in (38) on page 382.
27. Oyharçabal (1993) provides several arguments that the presence of an allocutive clitic in the auxiliary does not signal the presence of an additional argument in the sentence. For instance, this alleged argument cannot bind anaphors. Oyharçabal interprets these arguments as showing that the clitic cross-references a pro in a high A'-position.
28. The underlined forms of T in table 3 are in fact intransitive. This is due to the *g-/z-* constraint (Arregi and Nevins 2007), which bans certain combinations of first plural with second person clitics. In this particular case, it triggers the deletion of a first plural ergative clitic in the context of a second person absolutive clitic. As predicted by the analysis of the *have/be* alternation in Arregi (2004) outlined above, this triggers the insertion of the feature [-Have] in the auxiliary. Despite being derived from a transitive syntax, the auxiliary is, in the sense defined above, morphologically intransitive.
29. (45a) is a default entry in the sense that it does not realize person and number features of T. However, it has a very specific context that limits its insertion to forms with a participant proclitic. See section 6.3 below.
30. In some of these forms, the specific allomorph of default T that is used is different from what is described below due to the *g-/z-* constraint (see note 28). Specifically, in the context of a second person dative and a first plural ergative clitic, the latter is deleted. This triggers the insertion of [-Have] in T, which is realized as the default intransitive form *a* (42).

31. There is an apparent exception: transitive past T in the context of a first singular dative clitic is *o*, rather than *eun* (see Table 5). However, this is due to the fact that, as discussed in note 20, Ergative Metathesis is blocked in precisely this context in Zamudio, so that the participant ergative clitic is in its original enclitic position. Since the vocabulary entry for *eun* only applies in the context of a participant proclitic, it cannot be inserted in this case, and default *o* is used instead.

References

- Albizu, Pablo
1997 The syntax of person agreement. Ph.D. diss., Department of Linguistics, University of Southern California.
- Albizu, Pablo, and Luis Eguren
2000 An optimality theoretic account for "Ergative Displacement" in Basque. In *Morphological Analysis in Comparison*, Wolfgang U. Dressler, Oskar E. Pfeiffer, Markus A. Pöchtrager and John R. Rennison (eds.), 1–23. Amsterdam: John Benjamins.
- Anagnostopoulou, Elena
2003 *The Syntax of Ditransitives*. Berlin/New York: Mouton de Gruyter.
- Arregi, Karlos
2004 The *have/be* Alternation in Basque. Ms., University of Illinois at Urbana-Champaign. Available at <http://uiuc.edu/~karlos/have.pdf>.
- Arregi, Karlos and Andrew Nevins
2006 A Distributed Morphology analysis of present tense auxiliaries in Zamudio Basque. *Euskalingua* 9: 146–156. See: www.mendebalde.com.
2007 Obliteration vs. Impoverishment in the Basque *g-/z-* constraint. In *Proceedings of the 30th Annual Penn Linguistics Colloquium*, Tatjana Scheffler, Joshua Tauberer, Aviad Eilam and Laia Mayol (eds.), 1–4. (Penn Working Papers in Linguistics 13.1.) Philadelphia: Penn Linguistics Club. Available at <http://ling.auf.net/lingBuzz/000280>.
2008 Ergative Displacement in Basque: A second position requirement satisfied by Metathesis. Ms., University of Illinois at Urbana-Champaign and Harvard University. In preparation.
- Azkue, Resurrección María
1923 *Morfología Vasca*. Bilbao: Euskaltzaindia.
- Béjar, Susana and Milan Rezac
2004 Cyclic Agree. Ms., University of Toronto.
- Bonet, Eulália
1991 Morphology after syntax: Pronominal clitics in Romance. Ph.D. diss., Department of Linguistics and Philosophy, MIT.
- Bossong, Georg
1984 Ergativity in Basque. *Linguistics* 22(3): 341–392.

Calabrese, Andrea

- 2006 On absolute and contextual syncretism: remarks on the structure of paradigms and how to derive them. In *Inflectional identity*, Asaf Bachrach and Andrew Nevins (eds.), 156–205. Oxford: Oxford University Press.

Chomsky, Noam

- 2000 Minimalist inquiries: The framework. In *Step by Step: Essays on Minimalist Syntax in Honor of Howard Lasnik*, Roger Martin, David Michaels and Juan Uriagereka (eds.), 89–155. Cambridge, MA: MIT Press.
- 2001 Derivation by phase. In *Ken Hale: A life in language*, Michael Kenstowicz (ed.), 1–52. Cambridge, MA: MIT Press.

Embick, David and Rolf Noyer

- 2001 Movement operations after syntax. *Linguistic Inquiry* 32 (4): 555–595.

Fernández, Beatriz and Pablo Albizu

- 2000 Ergative displacement in Basque and the division of labor between morphology and syntax. In *The Proceedings from the Panels of the Chicago Linguistic Society's Thirty-Sixth Meeting*, Akira Okrent and John P. Boyle (eds.), 103–117. Chicago: Chicago Linguistic Society.

Gaminde, Iñaki

- 2000 *Zamudio Berbarik Berba*. Bilbo: Labayru Ikastegi. Also available at <http://bips.bi.ehu.es/manwe-bideoteka/zamudio/>.

Gómez, Ricardo and Koldo Sainz

- 1995 On the origin of the finite forms of the Basque verb. In *Towards a History of the Basque Language*; José Ignacio Hualde, Joseba A. Lakarra and R. L. Trask (eds.), 235–274. Amsterdam: John Benjamins.

Hale, Kenneth and Samuel Jay Keyser

- 1993 On argument structure and the lexical expression of syntactic relations. In *The View from Building 20: Essays in Honor of Sylvain Bromberger*, Kenneth Hale and Samuel Jay Keyser (eds.), 53–109. Cambridge, MA: MIT Press.

Halle, Morris

- 1997 Distributed Morphology: Impoverishment and Fission. In *PF: Papers at the Interface*, Benjamin Bruening, Yoonjung Kang and Martha McGinnis (eds.), 425–450. (MIT Working Papers in Linguistics 30.) Cambridge, MA: MITWPL.

Halle, Morris and Alec Marantz

- 1993 Distributed Morphology and the Pieces of Inflection. In *The View from Building 20: Essays in Honor of Sylvain Bromberger*, Kenneth Hale and Samuel Jay Keyser (eds.), 111–176. Cambridge, MA: MIT Press.
- 1994 Some key features of Distributed Morphology. In *Papers on Phonology and Morphology*, Andrew Carnie, Heidi Harley, and Tony Bures

(eds.), 275–288. (MIT Working Papers in Linguistics 21.) Cambridge, MA: MITWPL.

Harris, James and Morris Halle

- 2005 Unexpected plural inflections in Spanish: Reduplication and Metathesis. *Linguistic Inquiry* 36 (2): 192–222.

Heath, Jeffrey

- 1976 Antipassivization: a functional typology. In *Proceedings of the Second Annual Meeting of the Berkeley Linguistics Society*, 202–211. Berkeley, CA: Berkeley Linguistics Society.

Holguín, Justin

- 2007 The status of ergative case in Basque: A Minimalist approach. Bachelor's thesis, Reed College. Available at <http://ling.auf.net/lingBuzz/000449>.

Holmberg, Anders and Thorbjörg Hróarsdóttir

- 2004 Agreement and movement in Icelandic raising constructions. *Lingua* 114 (5): 651–673.

Hualde, José Ignacio

- 2002 On the loss of ergative displacement in Basque and the role of analogy in the development of morphological paradigms. In *The Linguist's Linguist: A Collection of Papers in Honour of Alexis Manaster Ramer, Volume 1*, Fabrice Cavoto (ed.), 219–230. Munich: Lincom Europa.

Kayne, Richard

- 1991 Romance clitics, verb movement and PRO. *Linguistic Inquiry* 22 (4): 647–686.

Laka, Itziar

- 1990 Negation in syntax: On the nature of functional categories and projections. Ph.D. diss., Department of Linguistics and Philosophy, MIT.
- 1993a The structure of inflection: A case study in X⁰ syntax. In *Generative Studies in Basque Linguistics*, José Ignacio Hualde and Jon Ortiz de Urbina (eds.), 21–70. Amsterdam: John Benjamins.

- 1993b Unergatives that assign ergative, unaccusatives that assign accusative. In *Papers on Case and Agreement I*, Jonathan D. Bobaljik and Colin Phillips (eds.), 149–172. (MIT Working Papers in Linguistics 18.) Cambridge, MA: MITWPL.

Larson, Richard

- 1988 On the double object construction. *Linguistic Inquiry* 19 (3): 335–391.

Marantz, Alec

- 1988 Clitics, morphological Merger, and the mapping to phonological structure. In *Theoretical Morphology: Approaches in Modern Linguistics*, Michael Hammond and Michael Noonan (eds.), 253–270. San Diego: Academic Press.

- 1993 Implications of asymmetries in double object constructions. In *Theoretical Aspects of Bantu Grammar*, Sam Mchombo (ed.), 113–150. Stanford, Calif.: CSLI.

- Müller, Gereon
2005 Pro-drop and Impoverishment. Ms., Universität Leipzig.
- Noyer, Rolf
1992 Features, positions and affixes in autonomous morphological structure. Ph.D. diss., Department of Linguistics and Philosophy, MIT.
2001 Clitic sequences in Nunggubuyu and PF convergence. *Natural Language and Linguistic Theory* 19(4): 751–826.
- Ormazabal, Javier and Juan Romero
2007 The Object Agreement Constraint. *Natural Language and Linguistic Theory* 25(2): 315–347.
- Ortiz de Urbina, Jon
1989 *Parameters in the Grammar of Basque: A GB Approach to Basque Syntax*. Dordrecht: Foris.
- Oyharçabal, Bernard
1993 Verb agreement with non arguments: On allocutive agreement. In *Generative Studies in Basque Linguistics*; José Ignacio Hualde and Jon Ortiz de Urbina (eds.), 89–114. Amsterdam: John Benjamins.
- Perlmutter, David
1971 *Deep and Surface Structure Constraints in Syntax*. New York: Holt, Rinehart and Winston.
- Pesetsky, David
1995 *Zero Syntax*. Cambridge, MA: MIT Press.
- Pylkkänen, Liina
2002 Introducing arguments. Ph.D. diss., Department of Linguistics and Philosophy, MIT.
- Rezac, Milan
2003 The fine structure of cyclic Agree. *Syntax* 6(2): 156–182.
2006 Agreement displacement in Basque: Derivational principles and lexical parameters. Ms., University of the Basque Country. Available online at <http://loargann.batcave.net/index.html>.
- Torreño, Esther
1992 Case and agreement structure. Ms., University of Massachusetts, Boston.
- Travis, Lisa deMena
1984 Parameters and effects of word order variation. Ph.D. diss., Department of Linguistics and Philosophy, MIT.
- Uriagereka, Juan
1995 Aspects of the syntax of clitic placement in Western Romance. *Linguistic Inquiry* 26(1): 79–123.
- Wiltschko, Martina
2008 Person hierarchy effects without a person hierarchy. In *Agreement restrictions* (this volume).

- Woolford, Ellen
2006 Lexical case, inherent case, and argument structure. *Linguistic Inquiry* 37(1): 111–130.
- de Yrizar, Pedro
1992 Morfología del Verbo Auxiliar Vizcaíno: Estudio Dialectológico. Bilbao: Euskaltzaindia.

Interface Explorations 15

Editors

Artemis Alexiadou
T. Alan Hall

Mouton de Gruyter
Berlin · New York

Agreement Restrictions

edited by

Roberta D'Alessandro
Susann Fischer
Gunnar Hrafn Hrafnbjargarson

Mouton de Gruyter
Berlin · New York